

MODEL PD686 3½ DIGIT NEMA 4X LOOP-POWERED METER



- 1 V Drop
- 1" High Display
- Operates Down to -40°C

SPECIFICATIONS

Except where noted all specifications apply to operation at +25°C.

INPUT: 4-20 mA @ 30 VDC maximum

DISPLAY: 1.0" (25.4 mm) LCD, 3½ digits; 1999

ACCURACY: ±0.1% FS ±1 count

APPROVALS: FM Approved & CSA Certified as intrinsically safe with entity, for use in Class I, II, III, Division 1, Groups A, B, C, D, E, F, & G; T-code = T4; hazardous locations. Non-incendive for use in Class I, II, III, Division 2, Groups A, B, C, D, F, & G.

ENTITY PARAMETERS: $V_{max} = 30$ V, $I_{max} = 175$ mA, $C_i = 0$ µF, $L_i = 0$ µH, $P_i = 1.3$ W

FM APPROVED: Intrinsically Safe, Class I Zone 0

See Control Drawing LIM686-2 for complete installation instructions.

DECIMAL POINT: User selectable

CALIBRATION: Two-step; non-interacting zero and span

CALIBRATION RANGE: 4 mA input: -1000 to +1000;

20 mA input: between 20 and 2000 counts > 4 mA display

DISPLAY UPDATE RATE: 2.5/second

MAXIMUM INPUT CURRENT: 30 mA

MAXIMUM VOLTAGE DROP: 1 V @ 20 mA

OPERATING TEMPERATURE: PD686: -40 to 85°C for Canadian installations -40 to 40°C.

STORAGE TEMPERATURE: -40 to 85°C

RELATIVE HUMIDITY: 0 to 90% non-condensing

ENCLOSURE: Impact-resistant glass filled polycarbonate body, color: gray; impact-resistant clear polycarbonate cover; NEMA 4X, IP67

CONNECTIONS: Removable screw terminals accept 12 to 26 AWG

CONDUIT HOLE: One ½" conduit hole provided; refer to Ordering Information to specify conduit hole location; request models with rear conduit hole (-X) for panel mounting applications.

WEIGHT: 12 oz (340 g)

WARRANTY: 2 years parts & labor

EXTENDED WARRANTY: 1 or 2 years

DISCLAIMER: The information contained in this document is subject to change without notice. Precision Digital Corporation makes no representations or warranties with respect to the contents hereof, and specifically disclaims any implied warranties of merchantability or fitness for a particular purpose.

ORDERING INFORMATION

Model	Description	½" Conduit Hole Location
PD686*	FM Approved & CSA Certified	Bottom
PD686-X	FM Approved & CSA Certified	Rear
PD686-Y	FM Approved & CSA Certified	Top
PD686-Z	FM Approved & CSA Certified	None

* Quick Shipment Product, shipped within 2 working days

ACCESSORIES

Model	Description
PDA6844	Panel Mount Kit (does not provide NEMA 4X seal to panel)
PDA6845	2" Pipe Mounting Kit (zinc plated steel)
PDA6845-SS	2" Pipe Mounting Kit (stainless steel)

SERVICES

Model	Description
PDN-CAL	Calibration with Certificate
PDN-CALDATA	Calibration with Certificate & Data
PDN-EXTWRNTY1-0	Extended Warranty 1 Year
PDN-EXTWRNTY2-0	Extended Warranty 2 Years
PDN-LTCAL5	Lifetime Calibration with Annual Recertification

YOUR LOCAL DISTRIBUTOR IS:

MODEL PD686 3½ DIGIT NEMA 4X LOOP-POWERED METER

Calibrator Connected to Input Signal PCB

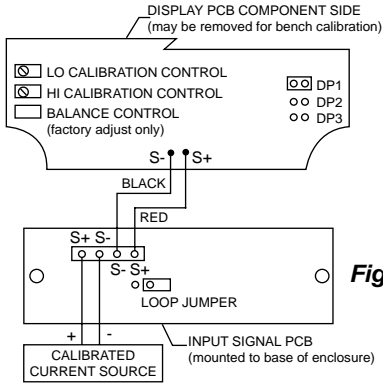

Figure 1

Control loop Connected to Input Signal PCB

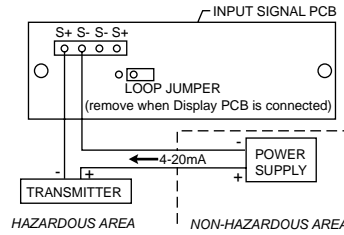

Figure 2

Field wiring is made to the Input Signal PCB which is mounted to the base of the enclosure.

Calibrator Connected to Display PCB

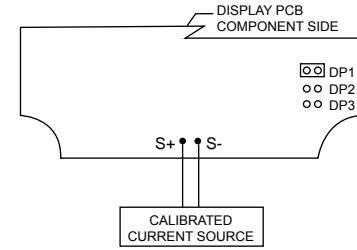

Figure 3

The Display PCB may be removed from the enclosure for bench calibration. Loop Jumper must be installed on Input Signal PCB to maintain loop, refer to procedures below.

Note: To maintain hazardous area protection, the input signal must always be connected to the Input Signal PCB, and not directly to the Display PCB.

Warning: Electrostatic hazard. Clean only with a moist cloth. Protect enclosure from exposure to chemical solvents and excessive ultraviolet (UV) light (e.g. sunlight).

NOTE 1: If any of the following operations are performed in the hazardous area, all appropriate hazardous area procedures must be followed.

NOTE 2: To prevent damage to electronic components caused by electrostatic discharge, a grounding strap should be worn when servicing the display.

SETUP

The only tools needed for calibration are a calibrated current source and a screwdriver.

Calibration Connections

To access the input terminals it is necessary to remove the enclosure cover and the Display PCB. This is done by loosening the four screws on the enclosure cover and removing the cover. Completely loosen the left screw that holds the Display PCB to the enclosure and loosen the right screw about four turns so the Display PCB remains attached to the enclosure. Rotate the Display PCB 90° to gain access to the Input Signal PCB. Next, connect a calibrated current source per Figure 1.

Decimal Point Selection

The decimal point jumper array is located in the lower right corner of the Display PCB next to the display. It is labeled DP1, DP2, DP3. Place a jumper over both pins of DP1 for a display of 199.9, DP2 for 19.99, or DP3 for 1.999.

Calibration

LO and HI calibration controls are located to the left of the display (see Figure 1). Apply a signal equal to 4 mA and adjust the LO control to display the desired reading. Apply a signal between 16 and 20 mA and adjust the HI control to display the desired reading. Complete the calibration procedure by making any minor adjustments to the LO and HI controls.

Installation

Installation of the meter involves removing the Display PCB from its enclosure and connecting a 1/2" conduit fitting to the hole provided. Refer to PD686 FM Approved & CSA Certified Loop-Powered Meter Intrinsic Safety Barrier Connections diagrams (LIM686-2) for further details. Wall mounting holes are located in each corner of the enclosure (see Figure 4).

Loop Connections

Disconnect power to the loop and install the meter as illustrated in Figure 2 and the PD686 FM Approved & CSA Certified Loop-Powered Meter Intrinsic Safety Barrier Connections diagrams (LIM686-2) supplied with the instrument. Replace the enclosure cover.

Removing Display PCB From the Loop

The Display PCB and Input Signal PCB are connected together with one black and one red wire. The wires are soldered to the Display PCB and connected to a screw terminal connector on the Input Signal PCB.

To remove Display PCB:

1. Loosen the four screws on the enclosure cover and remove the cover from the enclosure base.

2. Completely loosen the left-side screw holding the Display PCB to the enclosure and loosen the right-side screw four turns so the Display PCB remains secure to the enclosure.
3. Rotate the Display PCB 90° to gain access to the Input Signal PCB.
4. Install Loop Jumper over both pins to bypass Display PCB and allow the signal to flow through the Loop Jumper. The display turns off when jumper is installed.
5. Disconnect the black and red signal wires from the screw terminal connector.
6. Loosen completely the right-side screw and lift Display PCB from enclosure. Care should be taken to prevent static electricity from damaging the electronic circuitry.
7. Restore enclosure cover to the base to prevent contamination of components.

Restoring Display PCB to the Loop

1. Remove enclosure cover as described above in step 1.
2. Secure Display PCB to enclosure using right-side screw; do not tighten screw to allow rotation of Display PCB while accessing Input Signal PCB.
3. Connect red wire to S+ terminal and black wire to S- terminal, as shown in Figure 1.
4. Remove Loop Jumper to allow the signal to flow through Display PCB (save push-on jumper by placing over one pin only).
5. Tighten screws holding Display PCB and install enclosure cover.

Servicing Display PCB Outside the Loop

Two modes of input signal allow the user to remove the Display PCB for service without interrupting the loop as indicated above and operate the Display PCB at another location in a non-hazardous area. The loop remains connected to the Input Signal PCB while the Display PCB is absent for service. The user may operate the Display PCB at another location by connecting a signal to "S+" and "S-" wires on the Display PCB. Refer to Figure 3.

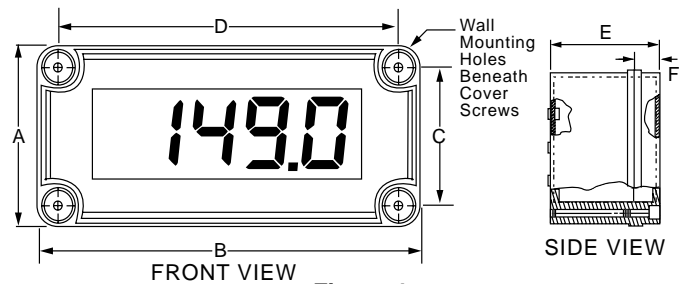

Figure 4

Dimensions and Wall Mounting Information

A: 3.15" (80 mm)	C: 2.36" (60 mm)	E: 2.56" (65 mm)
B: 5.51" (140 mm)	D: 4.72" (120 mm)	F: 0.79" (20 mm)

LIM686 Rev D 01/07

PD686 FM APPROVED & CSA CERTIFIED LOOP-POWERED METER Intrinsic Safety Barrier Connections

SECTION	AGENCY	DESCRIPTION
1.0		General Notes
2.0	FM/CSA	Conduit Installation Instructions
3.0	FM	Single or Dual Channel Positive Polarity Intrinsic Safety Barrier
4.0	CSA	Single or Dual Channel Intrinsic Safety Barrier Entity Installation

**NOTE: FM AND CSA CONTROLLED DOCUMENT.
NO CHANGES WITHOUT PRIOR FM AND CSA APPROVAL.**

1.0 GENERAL NOTES

- For Class II, Class III (Division 1 and 2) and NEMA/CSA type 4X installations, use conduit hub which is listed/certified for the environment in which the indicator is installed.
- For Class II and III (Division 1 and 2) installations, field wiring must enter the enclosure through a listed/certified dust-tight conduit seal.
- Control room equipment must not use or generate more than 250 VRMS or VDC.
- US installations must be in accordance with ANSI/ISA RP12.06.01 "Installation of Intrinsically Safe Systems for Hazardous (Classified) Locations" and the National Electrical Code (ANSI/NFPA 70). Canadian installations must be in accordance with the Canadian Electrical Code, Part 1.
- Hazardous location installation instructions for associated apparatus (barrier) must also be followed when installing this equipment.
- For safe installation of a FM Approved/CSA Certified transmitter in series with PD686 loop indicator, the hazardous location installation instructions for the transmitter, PD686 loop indicator, and associated apparatus (barrier) must be compatible.
- PD686 indicator does not add capacitance or inductance to loop under normal or fault conditions.
- Substitution of components may impair hazardous location safety.

2.0 PD686 CONDUIT INSTALLATION INSTRUCTIONS

- Remove the Display from the enclosure and connect 1/2" conduit fittings to the hole provided. For enclosures without a pre-drilled hole, the installer must make a hole in accordance with the instructions for the particular conduit fitting being installed.
- Use only UL/CSA conduit hubs that are specified to maintain NEMA 4X and Class II / Class III ratings.
- Conduit hubs must be connected to the conduit prior to being connected to the enclosure.
- Enclosure must be mounted using the mounting holes located in the base external to the equipment cavity.

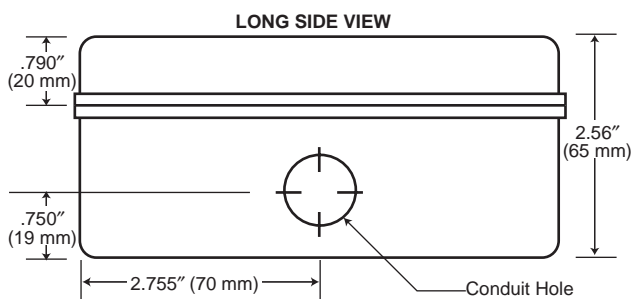

3.0 PD686 FM INSTALLATION WIRING DIAGRAM Using single or dual channel intrinsic safety barrier

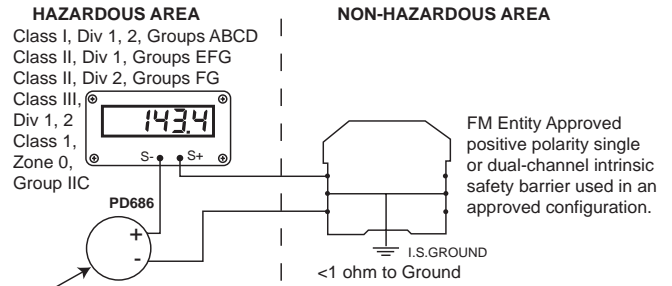

FM ENTITY APPROVED TRANSMITTER INSTALLED PER TRANSMITTER MANUFACTURER'S HAZARDOUS LOCATION INSTALLATION DRAWING

PD686 ENTITY PARAMETERS:
 U_i : 30 V; I_i : 175 mA; C_i : 0; L_i : 0; P_i : 1.3 W

Application Notes:

- $U_i > U_o$ of single channel barrier or V_t of dual channel barrier
- $I_i > I_o$ of single channel barrier or I_t of dual channel barrier
- L_i plus interconnecting wiring $< L_o$ of single or dual channel barrier
- C_i plus interconnecting wiring $< C_o$ of single or dual channel barrier
- It is not necessary to use intrinsic safety barriers when installing the PD686 in Class I,II,III, Division 2, Groups ABCDFG, maximum input voltage = 30 VDC.

4.0 PD686-CSA INSTALLATION WIRING DIAGRAM Using single or dual channel intrinsic safety barrier-entity installation

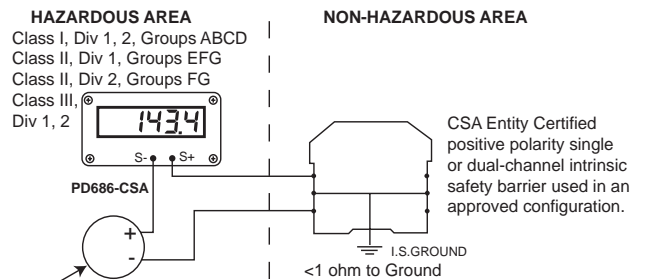

CSA ENTITY CERTIFIED TRANSMITTER INSTALLED PER TRANSMITTER MANUFACTURER'S HAZARDOUS LOCATION INSTALLATION DRAWING

PD686-CSA ENTITY PARAMETERS:
 V_{max} : 30 V; I_{max} : 175 mA; C_i : 0; L_i : 0; P_i : 1.3 W

Application Notes:

- Barrier parameters must meet the following requirements:
 V_{oc} or $U_o \leq V_{max}$ or U_i
 I_{sc} or $I_o \leq I_{max}$ or I_i
 C_a or $C_o \geq C_i + C_{cable}$
 L_a or $L_o \geq L_i + L_{cable}$
 $P_o < P_i$
- For CSA Certification, barrier and transmitter must be CSA Certified with Entity Parameters and must be connected per manufacturer's instructions.
- It is not necessary to use intrinsic safety barriers when installing the PD686-CSA in Class I,II,III, Division 2, Groups ABCDFG, maximum input voltage = 30 VDC.