

MicroTron

Series C

Chemical Metering Pump

Manual Stroke Adjustment

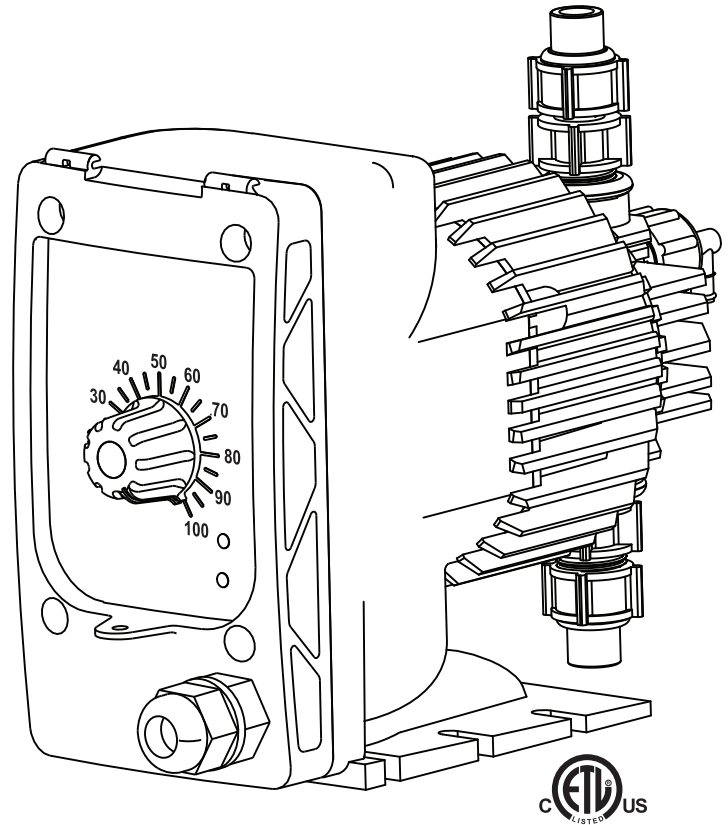

Key Features

- Single Output Adjustment
- NEMA 4X Style Enclosure
- Guided Double Ball Checks
- Circuit Protection
- Thermal Overload Protection
- Priming Valve Standard
- Microprocessor Fixed Speed
- 2 Year Warranty

Application

MicroTron Series C metering pumps provide reliable, economical chemical addition for a wide variety of applications.

Metering accuracy is achieved with microprocessor controlled preset speed and double ball guided checks. A rugged thermoplastic NEMA 4X style housing allows for outdoor installations.

The Series C pumps are available in outputs up to 30 GPD and 250 PSIG. The manual stroke length adjustment provides a simple turn down on all models.

Build a Model

Model C _ _ _ _ _ - _ _ _ _ _

Build your model number by selecting one code from each step. Example: C105X1-KVC1

STEP 1 OUTPUT (MAXIMUM)

105	=	5 GPD / 0.80 LPH	at	110 PSI (7.5 bar)
110	=	10 GPD / 1.60 LPH	at	110 PSI (7.5 bar)
115	=	15 GPD / 2.37 LPH	at	110 PSI (7.5 bar)
120	=	20 GPD / 3.15 LPH	at	110 PSI (7.5 bar)
130	=	30 GPD / 4.70 LPH	at	110 PSI (7.5 bar)
202	=	2 GPD / 0.31 LPH	at	250 PSI (17.2 bar)
205	=	5 GPD / 0.80 LPH	at	250 PSI (17.2 bar)
210	=	10 GPD / 1.60 LPH	at	250 PSI (17.2 bar)
215	=	15 GPD / 2.40 LPH	at	250 PSI (17.2 bar)
217	=	17 GPD / 2.60 LPH	at	250 PSI (17.2 bar)

STEP 2 CONTROL OPTIONS

- X = Standard
- E = External Pace
- F = Hall Effects Meter Input

STEP 3 VOLTAGE

- 1 = 120 Volt USA Plug
- 2 = 240 Volt
- 3 = 240 Volt Specified Plug

STEP 4 HEAD MATERIAL

- K = Kynar
- S = Stainless

STEP 5 SEAT MATERIAL

- V = Viton
- F = Teflon
- H = Hypalon

STEP 6 CHECK BALL

- C = Ceramic
- S = Stainless

STEP 7 CONNECTIONS

- 1 = 3/8" (9.525 mm) Tubing - 110 & 150 PSI
- 2 = 1/4" (6.35 mm) Tubing - 250 PSI
- 3 = 3/8" (9.525 mm) Tubing - 250 PSI
- P = 1/4" (6.35 mm) MNPT Connections
- V = 3/8" (9.525 mm) Vinyl Suction Tubing - 110 or 250 PSI

For other options, see Price List or consult factory.

Specifications

Electrical

- Input - 120 VAC or 240 VAC @ 50/60 Hz

Operational

- Stroke length adjustment - 10-100%
- Stroke speed frequency - Preset

Enclosure

Heavy duty NEMA 4X style high impact thermoplastic with clear lexan cover.

Environment

- Ambient temperature 32° to 140°F (0 to 60°C)
- Relative humidity 0 to 100%

Shipping Weight: Approximately 10 lbs. (4.536 kg)

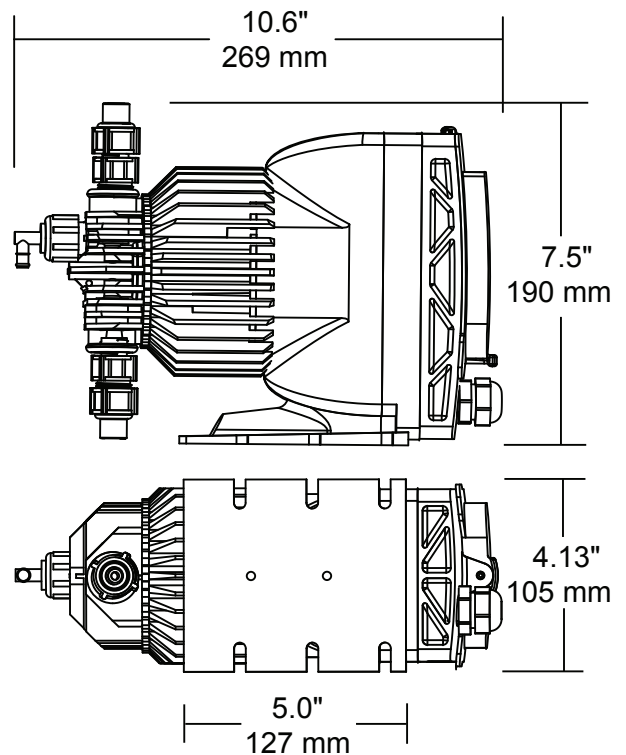

Get the Advantage



4700 Harold Abitz Dr
Muskogee, OK 74403
800-743-7431 phone
888-686-6212 fax
www.advantagecontrols.com