

# Series R

## Models RC & RD

Combination Metering Pump  
Conductivity Controller

***Installation  
Maintenance  
Repair  
Manual***

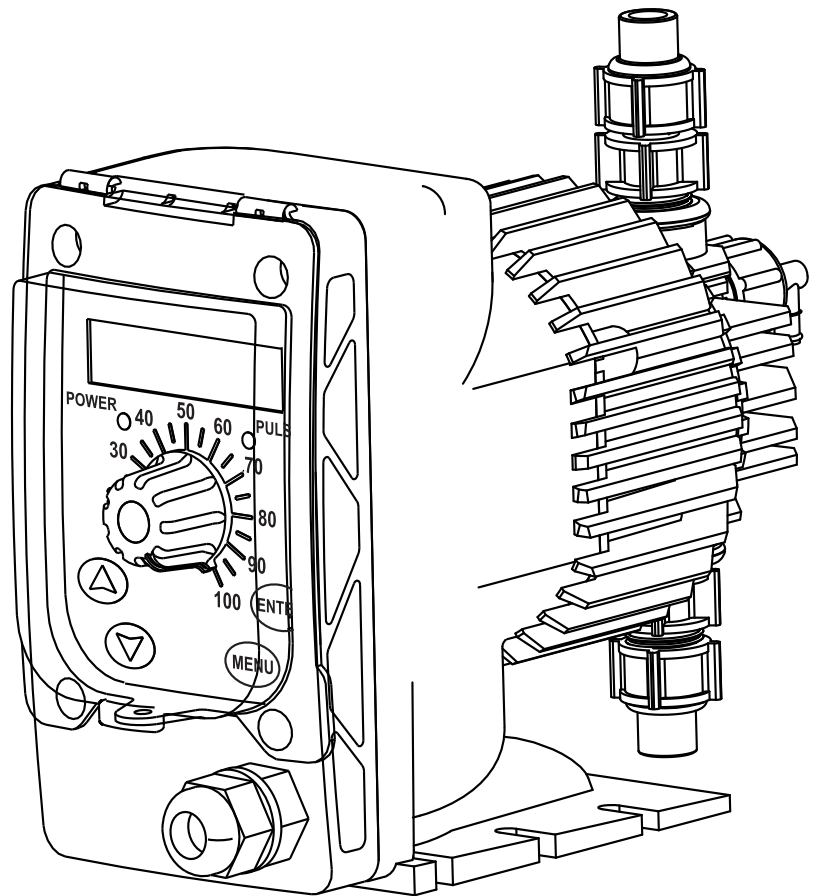

Advantage Controls  
P.O.Box 1472  
Muskogee, OK 74402  
Phone: 800-743-7431  
Fax: 888-686-6212  
[www.advantagecontrols.com](http://www.advantagecontrols.com)

# Model RC & RD Pump Instructions & Maintenance Manual Table of Contents

Contents	Page No.
I.	Introduction.....3
	Model Numbering .....3
II.	Unpacking .....4
III.	Safety Considerations .....4
	A. Chemical Compatibility.....4
	B. Safety Equipment and Preparation .....4
IV.	Installation .....4
	A. Location.....4
	B. Electrode Installation .....4
	C. Electrical.....5
	D. Chemical Injection Plumbing .....6
V.	Start-Up .....8
	A. Front Panel Description.....8
	B. Run Mode Explanation .....8
	C. Set-Up Mode Explanation .....9
	D. Priming the Pump.....9
	E. Adjusting Feed Rate.....9
	F. Stroke Length .....9
	G. Calculating Output.....9
	H. Conductivity Calibration.....10
VI.	Feed Timer Options for Model RD/RE .....10
VII.	Menu Maps.....11
	A. RC Menu Map .....11
	B. RD Menu Map .....12
	C. Model RE Biocide Timer Set-Up .....13
VIII.	Maintenance.....14
	A. Diaphragm Replacement.....14
	B. Suction and Discharge Check Valve Replacement... 14
	C. Cleaning Conductivity Probe .....14
	D. Liquid End Diagram.....16
	E. Replacement Parts.....17
IX.	Trouble Shooting .....18
X.	Warranty and Factory Service Policies .....19

# I. Introduction

This instruction manual covers all facets of operation of the Advantage Controls MicroTron™ electronic solenoid metering pump, including unpacking, mounting, electrical and plumbing connection, and start-up. Safety, maintenance and repair, warranty, and factory information are also provided. Please read this manual completely before proceeding. Observe safety protocols and heed all warnings and precautions.

## Model Numbering

MicroTron™ Series R pump model numbers define the output, pressure and control functions present on a particular pump. Your pump may be supplied with one or more of the options described in this manual. To determine what features apply to your pump, check the model number label located on the pump.

### Model Number Example

**R D 30 X 1 - P V C 1 - S**

#### Control Function

- C = Conductivity Feed and Bleed
- D = Conductivity Bleed with a Selectable Inhibitor Timer

#### Output

- 30 = 30 gallons per day at 110 psi
- 55 = 55 gallons per day at 75 psi
- 15 = 15 gallons per day at 150 psi
- 17 = 17 gallons per day at 250 psi

#### Stop Function Options

- X = Standard
- D = Auto Stop
- E = Flow Switch Assembly
- G = Flow Switch

#### Voltage

- 1 = 120 volt with USA plug (standard)
- 2 = 240 volt no plug
- 3 = 240 volt with specified plug
- L = 120 volt with US plug and no control relay pigtail

#### Pump Head Material

- P = Glass-Filled Polypropylene (standard)
- K = Kynar
- V = PVC

#### Seat Material

- V = Viton (standard)
- F = Teflon
- H = Hypalon

#### Check Ball

- C = Ceramic (standard)
- D = Ceramic single on discharge
- S = Stainless

#### Tubing Connections

- 1 = 3/8" PE, models up to 150 psi (standard)
- 2 = 1/4" PE, 250 psi models (standard)
- 3 = 3/8" PE on 250 psi models
- P = 1/4" MNPT
- V = 3/8" Clear flexible suction tubing

#### Special Options

- S = 3-function injection valve

**NOTE:** This list represents our most popular options. If you have an option not covered, contact the factory or your dealer for more details.

## II. Unpacking

The Advantage MicroTron™ pump has been shipped to you as a complete metering package, ready for installation. If shipping carton shows any signs of damage, notify the shipping company immediately upon receipt. Advantage Controls cannot be held responsible for damage from shipping. Unpack the carton and insure that the following items are present:

1. Metering pump
2. Suction, discharge and prime tubing
3. Foot valve and weight
4. Instruction manual
5. Injector fitting
6. Conductivity probe assembly

## III. Safety Considerations

**NOTE: All MicroTron™ pumps are primed with water before leaving the factory. If the pumped solution is not compatible with water, disassemble the fluid end and dry before use.**

### A. Chemical Compatibility

MicroTron™ metering pumps are designed to work with most liquid chemicals. A chemical resistance chart is available for determining specific compatibility with a wide variety of chemicals. If you have further compatibility questions, contact Advantage Controls service department at 1-800-743-7431.

### B. Safety Equipment and Preparation

Always wear the proper protective clothing and gear when working around chemicals and chemical metering pumps. Safety glasses, gloves, and aprons are critical in preventing accidental exposure to dangerous chemicals. Liquids under pressure can present a special hazard when a line or seal is punctured resulting in the spraying of chemical many yards away. If a chemical spill occurs, consult the Material Safety Data Sheet (MSDS) for specific instructions regarding the chemical being used.

## IV. Installation

### A. Location

The standard Model R is prewired for easy installation. Select a secure mounting location convenient to electrical and plumbing connections that is accessible by the operator. Do not install the pump in a location where the ambient temperature exceeds 120°F (50°C). The pump is suitable for most outdoor installations, shielding from direct exposure to the elements is recommended. The properties of solutions to be metered should also be considered concerning temperature changes and effects to poly tubing. Accessory item R00225 (plastic mounting bracket) is recommend for a secure installation.

### B. Electrode Installation

The standard Model R is provided with a TE-4A quick disconnect probe and T assembly on an 8' lead. The tee has ¾" female slip connections. The probe must be installed in a sample line having an inlet pressure higher than the outlet and 3-10 gpm flow for proper operation. Isolation valves on both sides of the probe assembly are needed to allow for easy removal of the probe for cleaning. See page 19 for probe and optional flow switch assembly diagrams.

**NOTE: We recommend using schedule 80 pvc piping for the entrie sample stream assembly. Using metal piping (copper, steel, etc), may cause electrical interference with the conductivity sensor.**

**Chemical injection must be down stream from the probe!**

### C. Electrical

1. The **Standard** MicroTron™ pump has a voltage regulated internal power supply capable of operating in the range of approximately 95 to 135 VAC. Use a supply voltage of 100 to 120 VAC for best results. The 3-wire grounded plug must be used in a 3-wire wall plug.
2. With a 240 volt option, the MicroTron™ pump has a voltage regulated internal power supply capable of operating in the range of approximately 195 to 260 VAC. Use a supply voltage of 210 to 250 VAC for best results. Pump is supplied without a country specific plug unless otherwise specified.

**CAUTION: Never remove ground wire from plug**

3. Control (bleed) relay output is equal to incoming line voltage with a 5 amp fused output.

**Note: An isolated circuit breaker with a true earth ground is highly recommended to insure uninterrupted operation.**

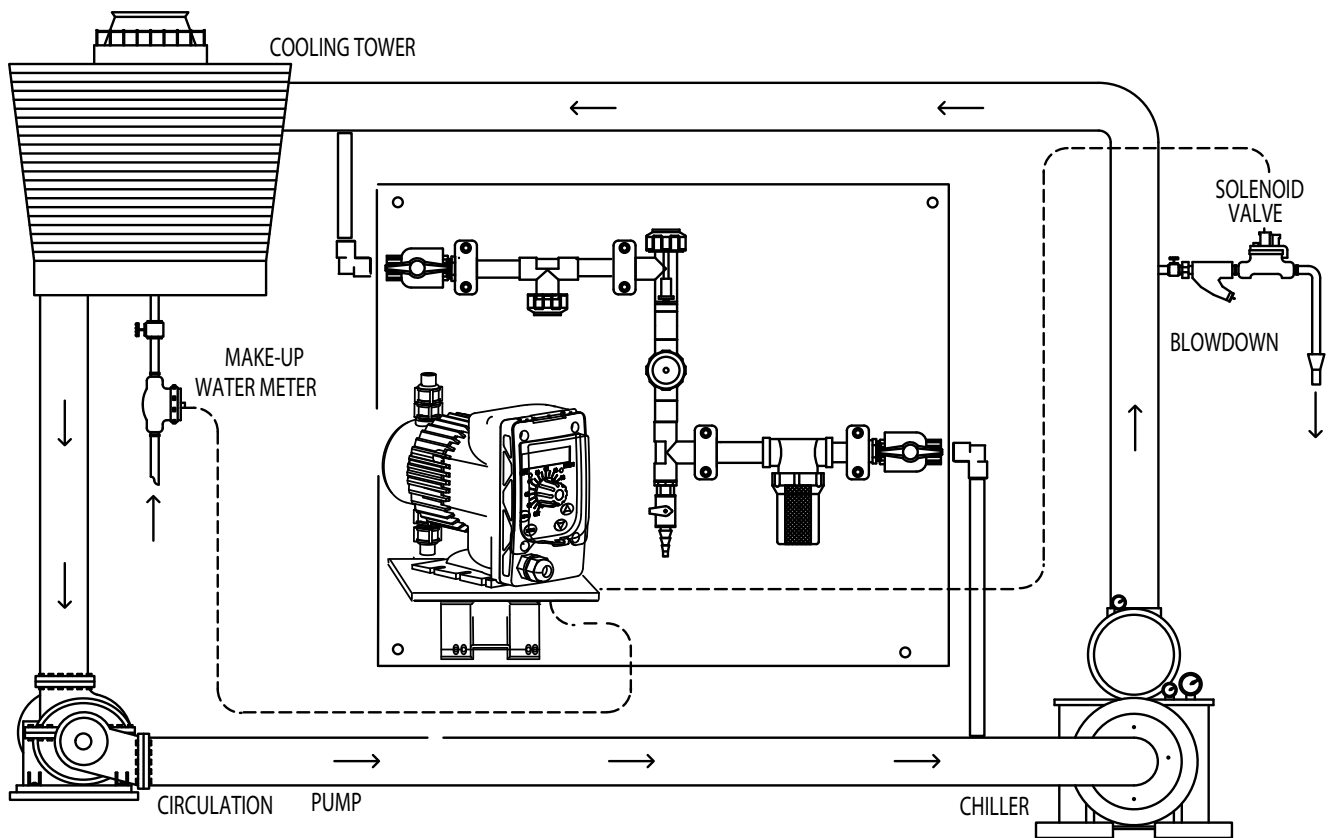

**Typical Installation**

**Note: A make-up water meter may or may not be used depending on model selected.**

## D. Chemical Injection Plumbing

### 1. Tubing Connections

The MicroTron™ pump uses carefully matched components to achieve a predictable metering output. This predictability can only be maintained if all fitting sizes remain unaltered. **Do not** attempt to reduce tubing size. All tubing connections should be double checked to insure against leakage. If hazardous chemicals are being pumped, use shielding around discharge tubing.

**NOTE:** When cutting lengths of tubing for your installation, ensure a clean, square cut. Use short lengths of tubing and as few connections as possible.

Do not overtighten the tubing connectors. Tighten the fittings no more than 1/4 turn after the fitting contacts the seal. Hand tighten only. **Do not use a wrench or pliers** as they may damage the fittings. Do not use Teflon tape except on NPT fittings. **Be sure to observe applicable local plumbing codes.**

**WARNING:** Clear flexible tubing is not intended for pressurized use.

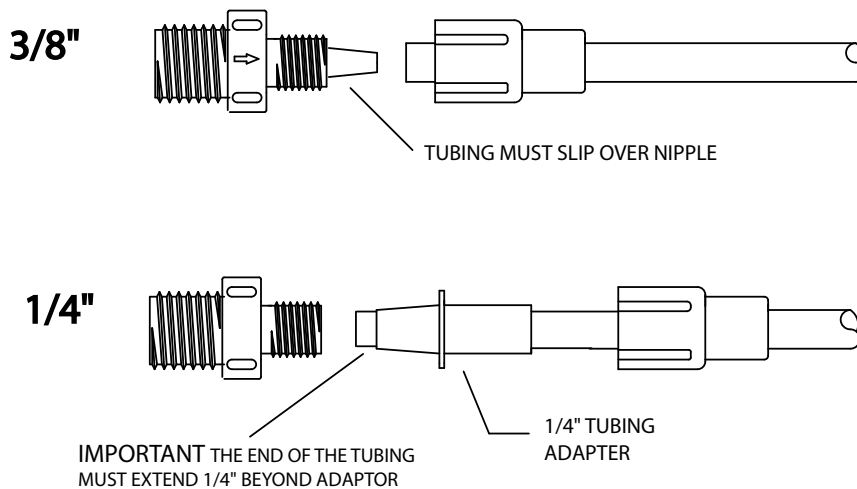

### 2. Suction Lift vs Flooded Suction Applications

#### Suction Lift Installation

Mount the MicroTron™ pump on the top of a molded tank, not to exceed 5 feet from pump to bottom of tank.

#### Flooded Suction

This installation is recommended for very low outputs, solutions that off-gas and high viscosity solutions. Priming is easier and loss of prime is reduced.

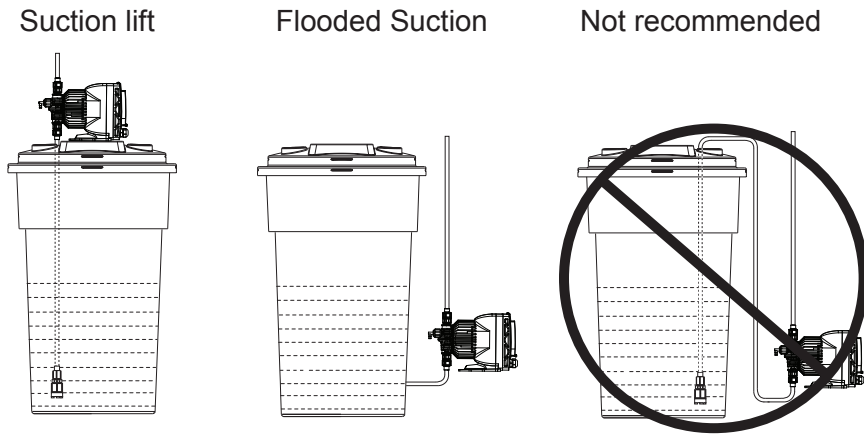

### 3. Wall Mounting

The fluid end portion (head assembly) of the pump is set up to accommodate mounting of the pump to the chemical container, either as a flooded suction, or a suction lift.

The pump head must be kept in a vertical position for proper operation. The head can be removed and rotated 90° if needed to keep the inlet and outlet valves in a vertical position.

### 4. Foot Valve Installation

A weight is provided to hold the tubing and foot valve in a vertical position at the bottom of the tank. **Do not allow the foot valve to lay horizontally in the chemical container.** This defeats the action of the valve and causes the pump to lose prime. Keep suction tubing reasonably short and avoid high spots or bends.

### 5. Injection Valve Installation

The injection valve is designed to prevent a back flow and to inject chemical into the line. To work properly, this valve must be mounted within 45 degrees of vertical (see drawing next page). One end of the injection valve is 1/2" MNPT. Install this end into the piping system. Use Teflon tape on the NPT threads of this fitting only.

Connect the pump's discharge tubing to the opposite end of the injector. Do not use Teflon tape or joint compound on this fitting. Connect tubing between this fitting and the pump discharge fitting at the pump.

**NOTE: When installation is made into a line with zero pressure or when pumping into an open vessel, use the optional three function injection valve which provides back pressure and anti-syphon capabilities.**

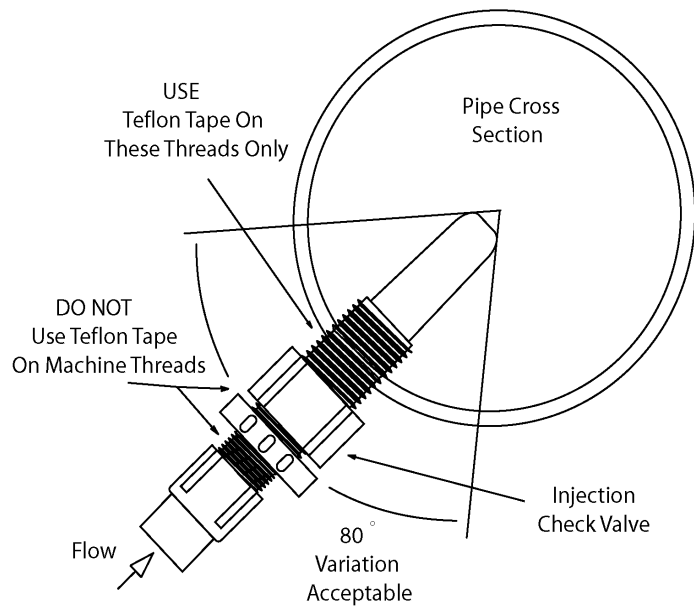

## 6. Optional Three Function Valve

The optional three function valve injection assembly provides the following three functions in one.

**Anti-siphon** feature allows metering of liquids “down hill” or into the suction side of a circulating pump. It provides protection against an accidental application of suction pressure at the injection point. The Teflon coated diaphragm provides a positive anti-siphon action.

**Back pressure** function permits metering into atmospheric discharge without over pumping.

**Line check** to permit the removal of discharge tubing without release of system fluid.

## 7. Priming / Degassing Valve Connection

Connect the clear poly tubing to the outlet of the bleed or priming valve. Position the free end of this tube in the chemical container, above the fluid level. This unique valve allows for the release of trapped air from the pump head when opened. Open valve all the way to quickly prime the pump, close it when primed. The valve can work as a degassing valve when the valve is left open approximately 1 turn.

# V. Start-Up

## A. Front Panel Description

All Model R pumps come with the following standard panel features:

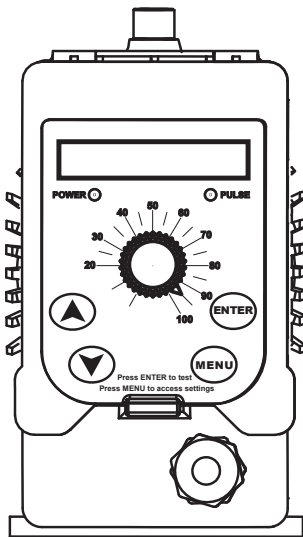

- 1x16-backlit LCD display
- On/Off power indicator light
- Pulse or Stroke indicator light
- Up and Down arrow keys for setting adjustments
- ENTER key to save desired adjustments
- MENU key to enter and exit pump set-up

## B. Run Mode Explanation

The readout will display one of two modes, Run mode or Set-up mode. Run mode is displayed only while the pump is on during normal operation. The screen will display the current conductivity value and indicate if it is calling for bleed. If conductivity functions are deactivated, the display will show the pump speed setting. Use the UP and DOWN arrow keys to monitor the current speed and length as well as timer settings when the pump is in RUN mode.

Pumps with control options can be forced into a priming for three minutes from the RUN mode by pressing the ENTER key. Pressing the ENTER key again during the priming cycle will put the pump back into the normal RUN mode. All adjustments for stroke frequency, optional timer settings and password information are made from the Set up mode.



### C. Set Up Mode Explanation

To enter Set up mode, press MENU. Notice that a cursor appears on the screen signifying that an adjustment can be made. To change the figure above the cursor press the UP or DOWN keys until the desired setting appears, then press ENTER to advance. Continue pressing ENTER to toggle past the other displays. When all settings are made, press MENU to return to run mode, and save settings.

**NOTE: RD pumps may require a password to enter MENU, see page 13.**

### D. Priming the Pump

Plug in pump, with pump stroking at 125 maximum strokes per minute set stroke knob to 100%. See stroke length instructions below and menu map on page 11. If fluid begins moving up suction line while pump is operating, no further priming is required. Otherwise, open bleed valve approximately one turn until fluid begins to move. When suction line fills, close bleed valve. **Do not over tighten bleed valve. Damage may occur.**

To prime pump, simply press and hold ENTER while the pump is in Run mode. This forces the pump to stroke at the rate of 125 strokes per minute for three minutes.

### E. Adjusting Feed Rate

The R pump allows for exact number of pulses to be set and read on the front panel LCD meter. It is adjustable from 0 to 125 strokes per minute. In addition, for applications requiring very low outputs the strokes per minute can be set in strokes per hour from 0 to 125. The 55 GPD models speed is 0-160.

### F. Stroke Length

The stroke length can be adjusted on all MicroTron™ pumps. This adjustment is a mechanical adjustment made using the large knob on the control panel. To avoid damage to the pump, this adjustment should only be made while the pump is running at a high stroking rate.

Always start adjusting your pump's output down by reducing the pump's speed. By leaving the stroke length as long as possible you decrease any chance of losing prime.

### G. Calculating Output

A pump's output per minute can be determined by dividing the maximum rated gallons per day by 1440 (minutes per day). For example, a 30 gallons per day (gpd) pump at a maximum stroke length and speed setting of 125 strokes per minute (spm) will pump 0.000167 gallons per stroke (gps).

$$30 \div 1440 = 0.0208 \text{ gpm} \div 125 \text{ spm} = 0.000167$$

With this value and the pump's speed setting (strokes per minute) you can calculate your pump's output at it's rated pressure. A 30 gpd pump set at 50 strokes per minute:

$$50\text{spm} \times .000167\text{gps} \times 1440 \text{ (minutes per day)} = 12.02 \text{ gallons per day}$$

Reducing the stroke length will reduce the pump's output again. If the example pump above has it's stroke length reduced to 50% the 12.02 gallons per day output is reduced to 6.01. (example: 12.02 gpd x 0.50 = 6.01 gpd) A higher product viscosity will reduce the output. Pressures lower than the pump's rating can increase output.

## H. Conductivity Calibration

All MicroTron™ model R conductivity units are factory calibrated for conductivity. The reading should be verified for accuracy and adjusted as per the instructions listed below.

Model R conductivity units can be calibrated by leaving the cleaned probe in a known solution and entering that value in the calibration screen of the menu. The zero point may be calibrated with the probe out-of-solution and dry by entering zero in the reset zero screen of the menu.

**See Set-Up Mode Menu Map on Page. 11.**

## VI. Feed Timer Options for Model RD

Model RD units include a user selectable chemical feed timer. The operator can choose one of the five different feed modes below that best meet the systems needs.

1. **No Timer** - This selection allows the pump to feed for the same amount of time as the unit bleeds.
2. **Lockout Timer** - Chemical feed is simultaneous with bleed. The timer can be set from 1-99 minutes and limits the amount of feed time to the timer setting during any bleed cycle preventing overfeed. If set to 0, the limit time is disabled.
3. **Post Bleed Timer** – Chemical feed occurs after a bleed cycle. The timer can be set for 0-100% of the post bleed time. The timer also has a total feed time limit, which can be set from 0-250 minutes.
4. **Pulse Timer** – This timer accepts pulses from a make-up contacting head water meter. It can accumulate 0-250 contacts to activate the feed timer. The timer can be set from 1 second to 10 minutes and 59 seconds.

**Note: A two wire cable connected to the pump is supplied for connecting to a contacting head water meter in the make-up water line. If this feed mode option is not selected, the cable will not be used and can be left unattached.**

5. **Percent Timer** – Chemical feed is turned on for 0-100% of a 10-30 minute repeating cycle time.
6. **28 Day Timer** – Chemical feed is turned on for an amount of time, but only on certain days.

**See Feed Timer Menu Map on Page 12**

# VII . Menu Maps

Use the ARROW keys to change options and the ENTER key to continue to next menu item.

Grayed out menu items are available only when FloTracker option is enabled.

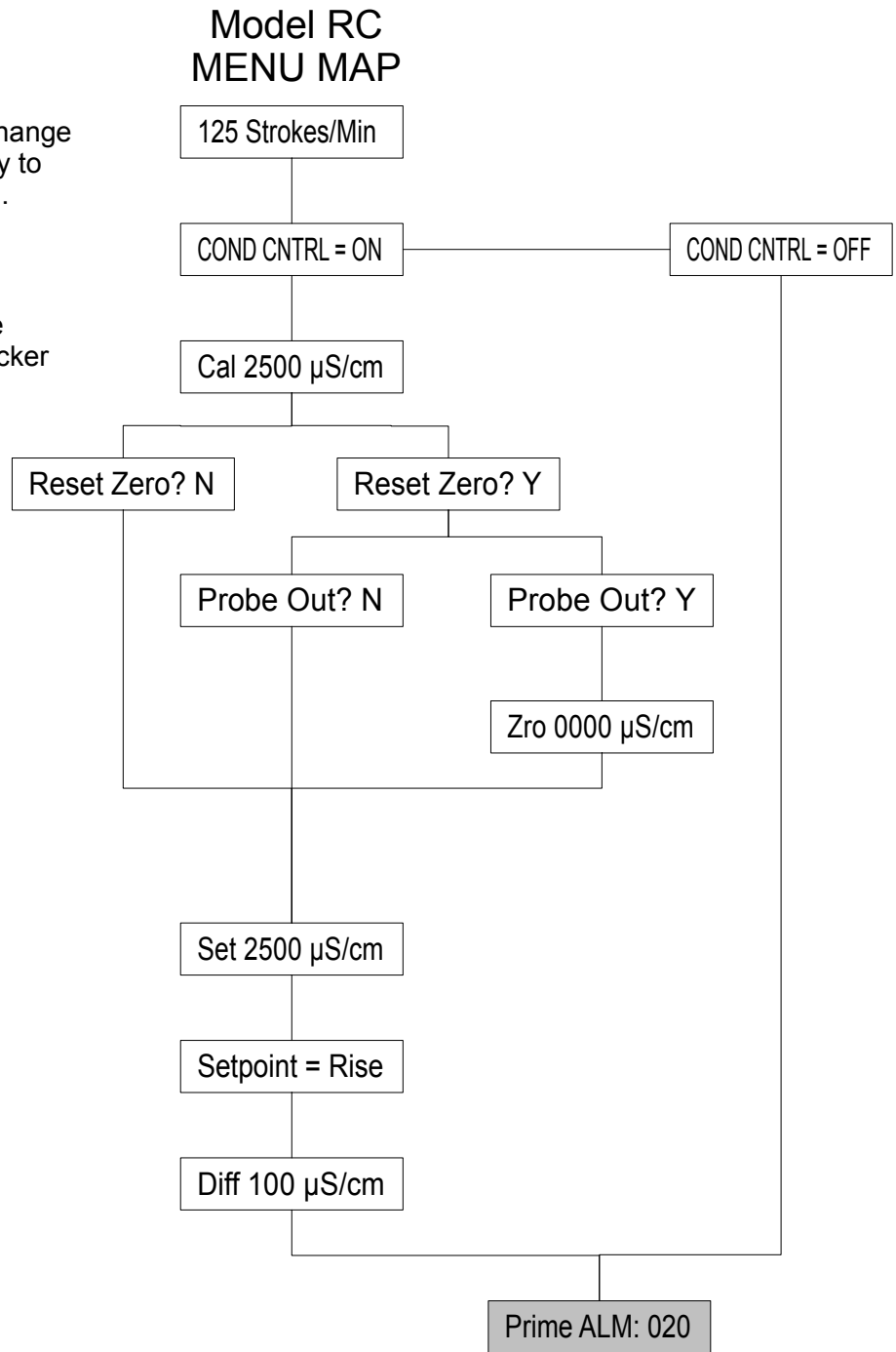

**NOTE:** Model RD pumps have additional menu steps shown on page 14 and 15.

Use the ARROW keys to change options and the ENTER key to continue to next menu item.

## Model RD MENU MAP

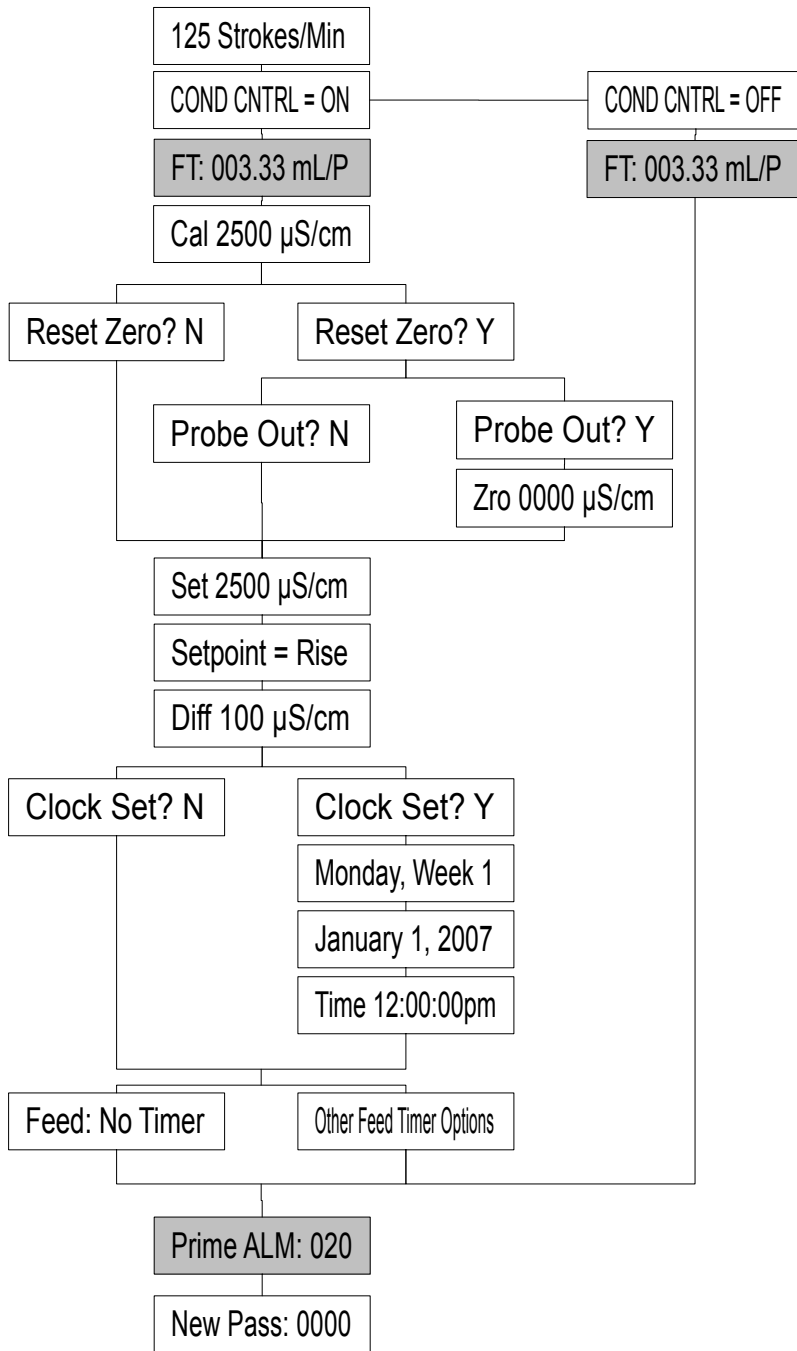

Grayed out menu items are available only when FloTracker option is enabled.

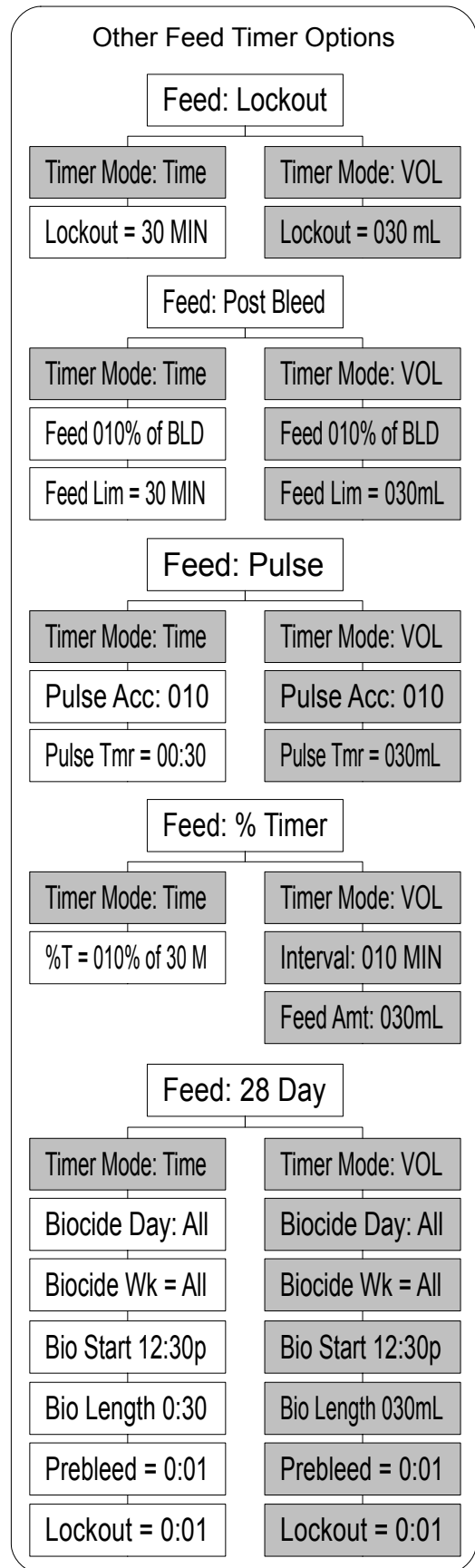

## Setting Pump Clock Settings

1. With display reading **Day HH:MM:SSpm** arrow in correct day of the week and press **ENTER**.  
The cursor will then be under the hour **HH** setting, arrow in correct hour taking note of the am/pm and press **ENTER** continue this process until the minutes, seconds and am/pm settings are complete.
2. With display reading **Wk=? Month Day, yy** arrow in the current week of a four week cycle and press **ENTER**. Continue this process to set the month, date and year.

## Setting Password

The display will show **New Password=0000**, arrow in desired four numbers pressing enter after each key. A value of 0000 will disable the password function.

## VIII. Maintenance

The MicroTron™ pump is designed for long service life with minimum maintenance. If for any reason, maintenance is necessary or desirable, the pump is easily maintained. Before any maintenance or service is performed, observe the following precautions:

1. Disconnect the MicroTron™ pump from power source.
2. Drain chemical from all tubing.
3. Disconnect discharge tubing from pump.
4. Observe relevant safety protocols when handling parts which have been in contact with hazardous chemicals.

**NOTES:**

1. **Tighten pump head screws after pump's initial week of operation.**
2. **When installing check valves, remember that the seats are always installed at the bottom.**

### A. Diaphragm Replacement

1. Remove fluid end cover by lightly prying it loose from the fluid end.
2. Remove the four screws attaching the fluid end to pump body.
3. Remove the fluid end from the pump body.
4. Unscrew the diaphragm from the pump shaft in a counter-clockwise direction.
5. Do not allow sharp or abrasive objects to come in contact with pump parts.
6. Inspect end of shaft to assure that threads are in good condition.
7. Screw new diaphragm onto pump shaft until it bottoms out on shoulder of shaft. Then back off 1/2 turn. It is not necessary to tighten further.
8. Replace fluid end. Make sure that screws are evenly tightened.
9. Replace fluid end cover.
10. Reconnect plumbing and power. Prime the pump.

### B. Suction and Discharge Check Valve Replacement

1. Disconnect suction tubing from pump.
2. Unscrew fitting from pump head.
3. Remove check valve from suction fitting and replace.
4. Remove O-ring from cavity in fluid end.
5. Remove check valve from suction side of pump and replace.
6. Install new O-ring in suction cavity of fluid end.
7. Replace suction fitting with check valve in fluid end.
8. Replace fluid end. Make sure that screws are evenly tightened.
9. Reconnect plumbing and power. Prime the pump.

### C. Cleaning Conductivity Probe

1. Record the current conductivity reading.
2. Turn off water flow through the electrode, bleed pressure from the line and remove electrode.
3. Use a clean cloth and a mild cleaning solution to remove loose dirt etc., from the flat surface of the electrode.
4. If the electrode has deposits such as scale attached to the electrode surface a more aggressive cleaning approach will be needed. There are several ways to do this, the preferred method being the one that is easiest for the user.
  - a. Use a mild acid solution to dissolve deposits.

- b. Use a pocket knife with a flat blade to scrape across the probe surface PERPENDICULAR to the carbons.
  - c. Lay a piece of sandpaper (200 grit or finer) on a flat surface such as a bench top. "Sand" electrode to remove stubborn deposits. (Do not wipe surface with your finger. Oil from your skin will foul carbon tips).
5. Reinstall the electrode in the system. After the reading stabilizes, calibrate the unit to a reliable test reading.

Many times an electrode can appear to be clean, but the unit still cannot be calibrated. If this is the case, use one of the more aggressive electrode cleaning procedures listed in step 4 above. Recheck the calibration after completion of this procedure. If no change was observed in the reading, replace the electrode. If a change occurred but the unit still will not calibrate, repeat procedure as many times as necessary.

### A. Standard TE-4A Electrode

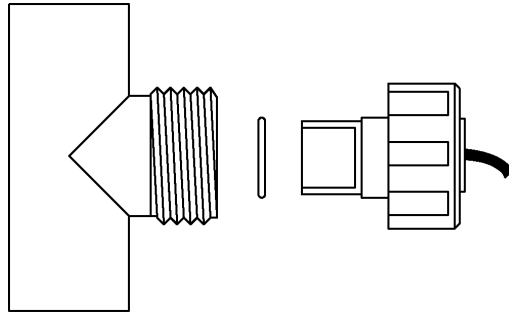

### B. Optional Flow Switch Assembly

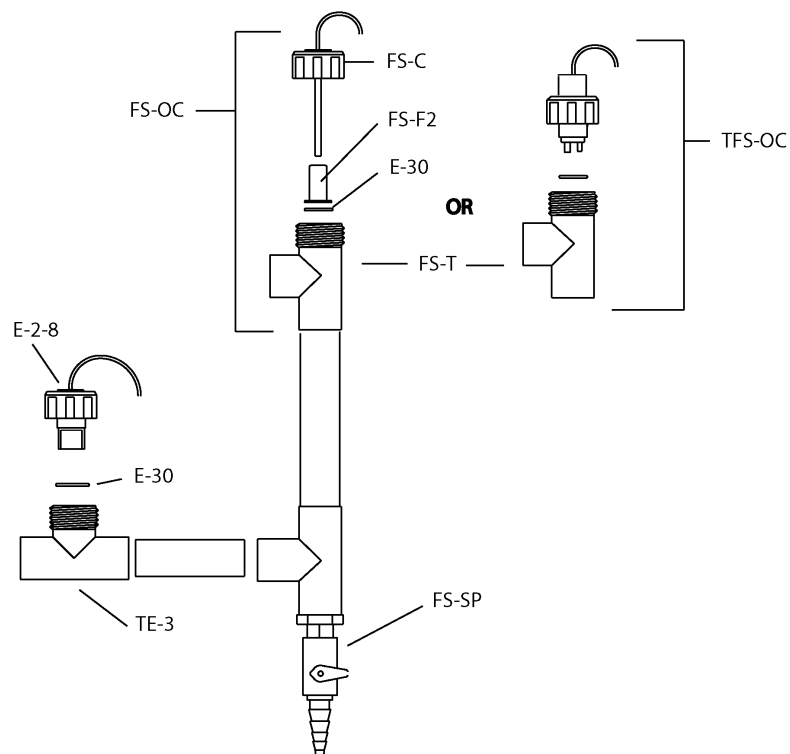

## D. Liquid End Diagram

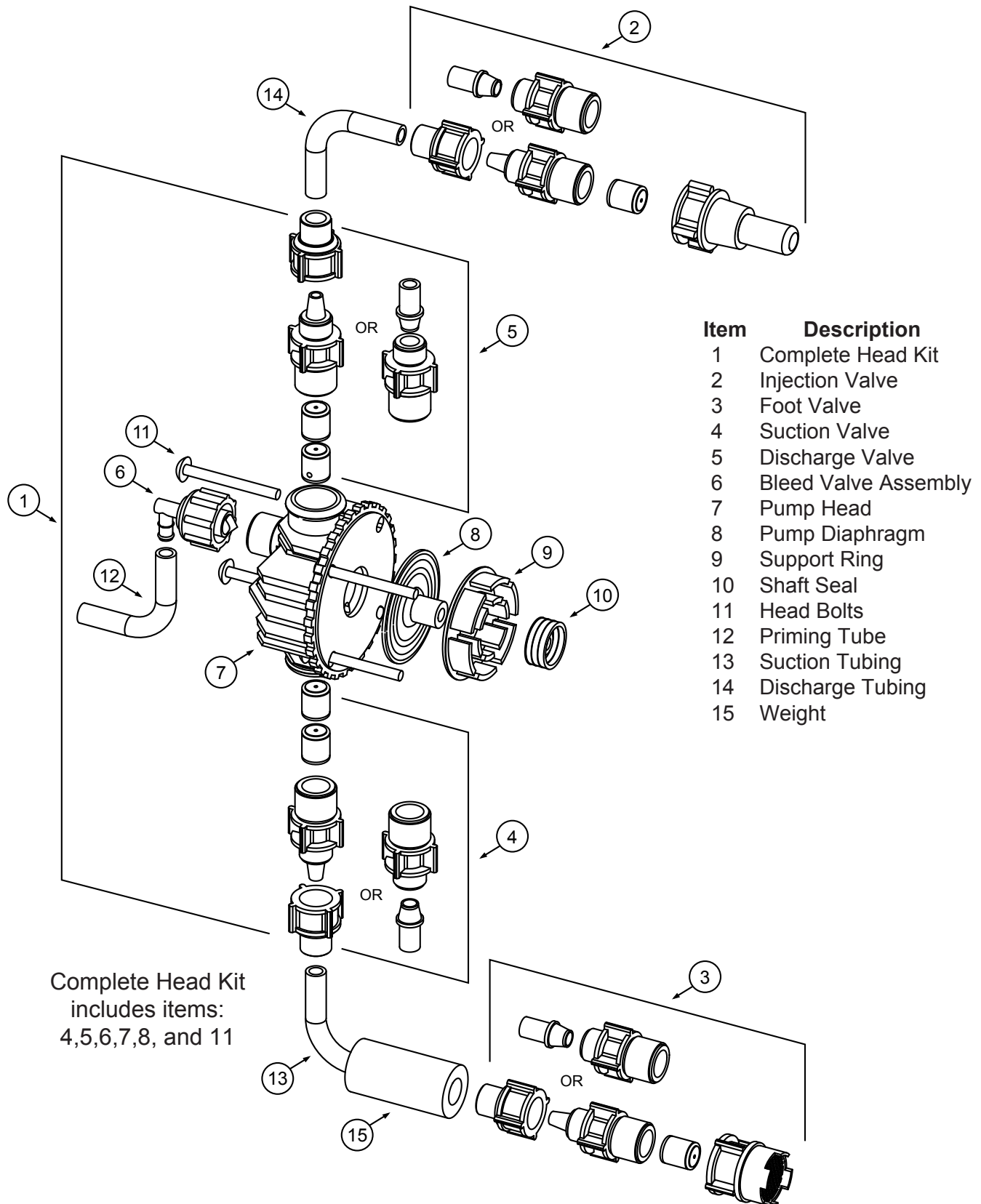



## E. Replacement Parts

Getting the right materials of construction for your spare parts is easy. Using positions 7-10 of the pump model number, example: RC130X1-**PFCV**. Find the assembly needed and add the codes of your pump's liquid end after the standard prefix part number for the assembly.

**Note:** For standard pumps using the short model number (example: RC130) use the following liquid end codes.

- a. 110 psi models use **-PVC1**.
- b. 250 psi models use **-PVC2**.

### Part Assemblies

Item	Description	Part Number
1.....	Complete Head Assembly 110 psi .....	CKR-1- _____
.....	Complete Head Assembly 150 & 250 psi .....	CKR-2- _____
2.....	Injection Valve Assembly.....	INJ- _____
Optional .....	3-Function Injection Valve .....	3FV- _____
3.....	Foot Valve Assembly.....	FTV- _____
4.....	Suction Valve Assembly.....	SUC- _____
5.....	Discharge Valve Assembly.....	DIS- _____
6.....	Priming Valve Assembly.....	PRI- _____

<u>Body</u>	<u>Seat</u>	<u>Ball</u>	<u>Connection</u>
P- Glass-filled Poly	V- Viton	C- Ceramic	1- 3/8" Tube
K- Kynar	F- Teflon	D- Single	2- 1/4" Tube
V- PVC	H- Hypalon	S- Stainless	3- 3/8" Tube
			K- 3/8" Tube
			P- 1/4" Pipe
			U- 3/8" UV
			V- 3/8" Clear Suction

### Single Parts

7.....	Pump Head 110 psi.....	R00026 - ___
.....	Pump Head 150 & 250 psi .....	R00039 - ___
8.....	Diaphragm 110 psi.....	R00007
.....	Diaphragm 150 & 250 psi.....	R00006
9.....	Support Ring 110 psi.....	R00069
.....	Support Ring 150 & 250 psi .....	R00068
10.....	Shaft Seal.....	R00050
11.....	Head Bolts.....	R00045
12.....	Priming Tubing .....	R00255
13.....	Suction Tubing 3/8" Clear .....	R00255
.....	Suction Tubing 3/8" PE .....	R00122
.....	Suction Tubing 1/4" PE .....	R00097
14.....	Discharge Tubing 3/8" PE.....	R00122
.....	Discharge Tubing 1/4" PE.....	R00267
15.....	Weight, Suction Tubing .....	R00139

## IX. Trouble Shooting

PROBLEM	CAUSE	REMEDY
<p>Pump does not achieve or maintain prime</p>	<p>Air trapped in suction line</p> <p>Foot valve contaminated or improperly installed</p> <p>Excessive lift</p> <p>Suction fittings not properly tightened</p> <p>Worn or contaminated check valves</p> <p>Split or pinch in suction tube</p> <p>Low chemical level</p>	<p>Straighten suction line so as to eliminate high spots.</p> <p>Inspect foot valve screen and assure that foot valve is in a vertical position below fluid level.</p> <p>Maximum suction lift is 5 feet with water or fluids of similar specific gravity; less with heavier liquids such as acids. Mount pump in a lower position relative to the chemical container.</p> <p>Check fittings. Overtightening may cause restriction. Conversely, if <b>any</b> leakage occurs, pump will suck air and fail to prime.</p> <p>Inspect check valves in fluid end for cleanliness. Clean or replace as necessary.</p> <p>Inspect suction tube through its full length to assure that there are no splits at the connections or other restrictions.</p> <p>Move any objects or equipment which impinges upon suction tube or reroute as required to assure a smooth transition from foot valve to pump.</p> <p>Check fluid level in chemical supply tank.</p>
<p>Insufficient fluid</p>	<p>Stroke adjustment set too low</p> <p>Worn or contaminated check valves</p> <p>Obstruction in suction line</p> <p>Clogged foot valve screen</p> <p>Output (system) pressure too high</p> <p>Diaphragm worn or torn</p> <p>Electronic failure</p>	<p>Check operation of stroke limiter knob. If pump delivers too low adjustable rate, check settings. Readjust as required.</p> <p>Inspect, clean or replace as necessary.</p> <p>Check suction line for obstructions, clogging, kinks or pinch points.</p> <p>Clean or replace foot valve screen.</p> <p>Relocate the injector to a lower pressure part of the the system.</p> <p>Replace diaphragm, making sure that it is screwed on fully to shoulder of shaft.</p> <p>Consult dealer or factory.</p>
<p>Excessive fluid</p>	<p>Failure or lack of antisiphon valve</p> <p>Excessive stroke rate</p> <p>Improper stroke length</p>	<p>Inspect or add anti-siphon valve. This is caused when system is in a vacuum condition or valve in delivery applications with flooded suction which feeds systems at very low pressures.</p> <p>Lower the stroke rate if adjustable on your pump.</p> <p>Reduce stroke length.</p>

<b>PROBLEM</b>	<b>CAUSE</b>	<b>REMEDY</b>
Pump will not pump	System pressure too high  Diaphragm improperly installed  Check valves worn or clogged	Check system pressure to assure that it is within system rated parameters of the pressure.  Make sure that diaphragm is screwed fully onto shaft.  Clean or replace as required.
Pump will not run or not plugged in	Pump not turned on or not plugged in  Electronic failure	Check outlet with meter to assure the correct voltage is present and that power supply cord is in good condition and plugged in. See page 5. Consult dealer or factory.
Excessive noise	Pump not primed  No output pressure	Prime pump.  Add an anti-siphon valve to provide 25 PSI restriction on pump discharge.

## **X. Manufacturer's Product Warranty**

Advantage Controls warrants units of its manufacture to be free of defects in material or workmanship. Liability under this policy extends for 24 months from date of installation. Liability is limited to repair or replacement of any failed equipment or part proven defective in material or workmanship upon manufacturer's examination. Removal and installation costs are not included under this warranty. Manufacturer's liability shall never exceed the selling price of equipment or part in question.

Advantage disclaims all liability for damage caused by its products by improper installation, maintenance, use or attempts to operate products beyond their intended functionality, intentionally or otherwise, or any unauthorized repair. Advantage is not responsible for damages, injuries or expense incurred through the use of its products.

The above warranty is in lieu of other warranties, either expressed or implied. No agent of ours is authorized to provide any warranty other than the above.

### **30 Day Billing Memo Policy**

Advantage Controls maintains a unique factory exchange program to ensure uninterrupted service with minimum downtime. If your unit malfunctions, call 1-800-743-7431, and provide our technician with Model and Serial Number information. If we are unable to diagnose and solve your problem over the phone, a fully warranted replacement unit will be shipped, usually within 48 hours, on a 30 Day Billing Memo.

This service requires a purchase order and the replacement unit is billed to your regular account for payment.

The replacement unit will be billed at current list price for that model less any applicable resale discount. Upon return of your old unit, credit will be issued to your account if the unit is in warranty. If the unit is out of warranty or the damage not covered, a partial credit will be applied based upon a prorated replacement price schedule dependent on the age of the unit. Any exchange covers only the controller or pump. Electrodes, liquid end components and other external accessories are not included.

# Get the Advantage in Water Treatment Equipment

Advantage Controls can give you the *Advantage* in products, knowledge and support on all of your water treatment equipment needs.

- Cooling Tower Controllers
- Boiler Blow Down Controllers
- Blow Down Valve Packages
- Solenoid Valves
- Water Meters
- Chemical Metering Pumps
- Corrosion Coupon Racks
- Chemical Solution Tanks
- Solid Feed Systems
- Feed Timers
- Liquid Level Controllers
- Glycol Feed Systems
- Pre Fabricated Systems

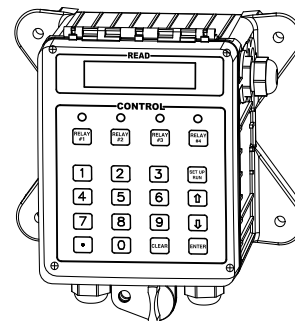
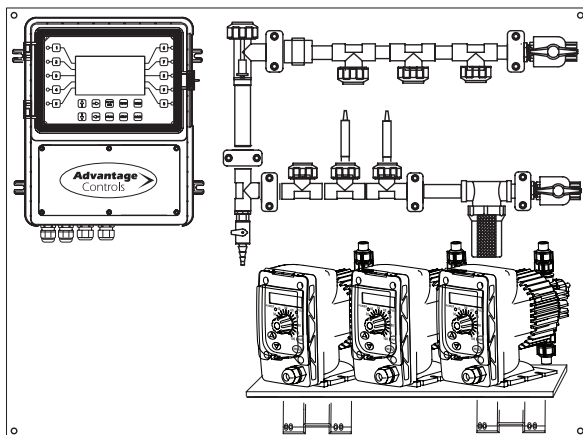
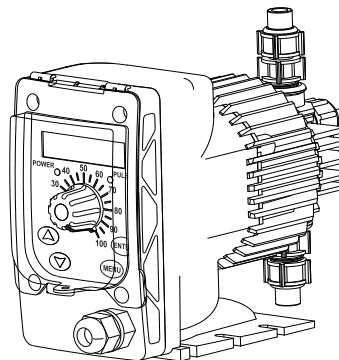
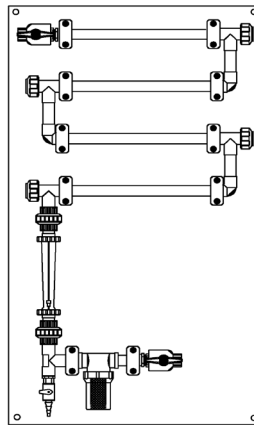
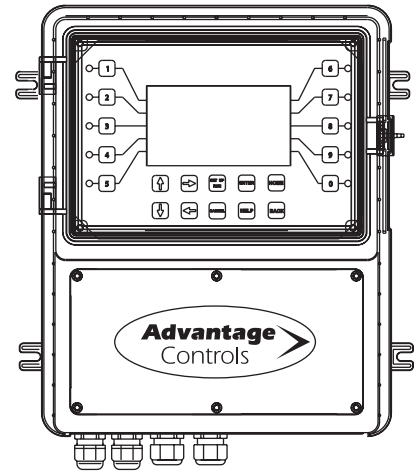
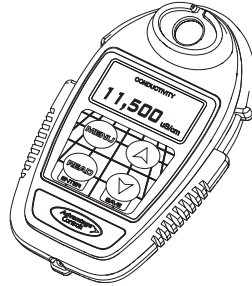

Get the Advantage

