

NanoTron

Conductivity

Installation
Maintenance
Repair
Manual

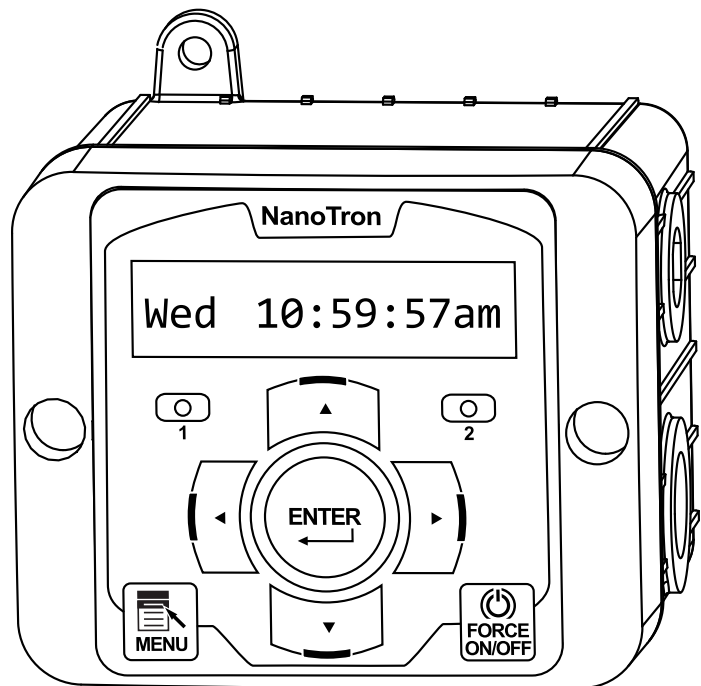

Advantage Controls
P.O. Box 1472
Muskogee, OK 74402
Phone: 800-743-7431
Fax: 888-686-6212
www.advantagecontrols.com
email: support@advantagecontrols.com

7/2014

Table of Contents

Contents	Page
I. Introduction.....	3
II. Description.....	3
NanoTron-C & B2 Features.....	3
III. Installation	
Electrical Wiring.....	4
Mounting Instructions.....	4
Logic and Relay Cards.....	5
IV. Front Panel Description.....	9
V. System Operation Overview.....	9
Description of Menus.....	9
Conductivity Sampling Methods.....	10
A. Continuous	
B. Timed Samping	
C. Sample and Hold	
Calibration Overview.....	10
A. Continuous	
B. Timed Samping	
C. Sample and Hold	
VI. Maintenance.....	11
VII. Troubleshooting.....	11
VIII. NanoTron-C & B2 Menu Map.....	12
IX. Warranty & 30 Day Billing Memo Policy.....	14

I. Introduction

NanoTron microprocessor based controllers are designed to provide a wide range of control functions for recirculating water treatment systems. The controller is programmed through a front panel keypad and can be configured to provide a customized control system for your application. Your particular unit's functions can be determined by comparing the units model number to the Model Numbering table listed below.

Model Numbering

NanoTron units have several base system control functions and unit optional features. Your unit may be supplied with one or more of the features described in this manual. To determine what features apply to your unit check the model number label located on the controller enclosure.

Base Control Function

- C** - Tower Conductivity and 1 Feed Timer
- B2** - Boiler Conductivity and 1 Feed Timer

Whole Unit Optional Features

- A** - Conduit Connections
- A3** - Conduit with CE
- E** - Flow Switch
- Y** - ETL Listing / Approvals

II. Description

NanoTron units are designed to automate conductivity control and / or the addition of various chemicals or activate other devices via a relay output.

Nano-C and Nano-B2 units include:

- * One totalizing water meter input that can be configured for contacting head or hall effect meter inputs.
- * One drum level input that can be set to disable the feed relay output.
- * Two mechanical relay outputs with normally open and normally closed contacts that can be configured for powered or dry contact relay operation (see page 4 diagram).
- * A "force on" timer that allows for manual activation of the relays for a user defined amount of time.

Conductivity Control (C & B) - Conductivity monitoring and control of Total Dissolved Solids (TDS) in a recirculating water systems in terms of electrical conductivity measured in MicroSiemens/cm. The conductivity scale can be selected from three ranges (low, mid and high) in the Configure menu (see page 13). One selectable feed timer is also included (see timer description below).

Feed Timer - One user selectable timer that can be individually programmed as one of the following types:

1. **Pulse Timer** – Accepts dry contact pulses from a water meter (supplied separately). It can accumulate 1-9999 pulses to activate the timer to run from 0-99 minutes, 59 seconds in minutes and seconds. Timer will store up to 5 additional activations during an individual run time.
2. **Recycle Timer** – Provides a user defined "off" cycle in HH:MM and a user defined "on" cycle in MM:SS that is repeated constantly.
3. **28-Day Timer** - 28-day feed timers, typically used for biocide feed are based on a 28-day cycle with two independent programmable feed cycles allowing for feed on selectable days and weeks.
4. **Batch Timer** - Timer activated by the Force On/Off key for a user defined run time.
5. **Reminder Timer** - Provides a 1-99 day cycle reminder alarm.
6. **Post Bleed Timer** - The relay is activated after a bleed cycle and runs for the set percentage of that bleed cycle.
7. **With Bleed Timer** - Activates the relay output simultaneously with the bleed and limits the amount of time the relay output will be on during the bleed cycle.

III. Installation

Electrical Wiring

The controller has an internal regulated power supply that will operate in the range of approximately 100 to 240 VAC on the incoming wiring. Output relay(s) are protected with a replaceable fuse. Relay output voltage will equal the incoming line voltage.

Prewired units are supplied with a 16 AWG cable with a 3-wire grounded USA 120 volt plug for incoming power and 18 AWG 3-wire grounded receptacle cords for all control relay outputs. Conduit units are supplied with liquid tights and adaptors for easy hard wiring to supplied connector.

NOTE: Liquid tight fittings and some labeled signal leads are provided for signal (low voltage) connections, such as water meter inputs.



WARNINGS

1. The controller should be connected to its own isolated circuit breaker, and for best results, the ground should be a true earth ground, not shared. Wiring must be done according to all applicable local codes.
2. Power (line voltage) must be disconnected while making any connections. If power is supplied to the unit, line voltage will be present on the relay cards.
3. Low voltage signal wires (probes, flow switch, water meter, etc.) should never be run in conduit with high voltage wires.
4. Hall effect meters that require +12 VDC must use an external power supply (TFS-PWR).

Mounting Instructions

Select a mounting location that provides the operator easy access to the unit and a clear view of the controls through the cover of the controller. The location should be convenient to grounded electrical connections, the needed sample line plumbing and is on a stable vertical surface.



WARNING: Avoid locations that expose the controller to direct sunlight, vapors, vibration, liquid spills or extreme temperatures; less than 0°F (-17.8°C) or greater than 120°F (50°C). EMI (electromagnetic interference) from radio transmissions and electric motors can also cause damage or interference and should be avoided.

Logic and Relay Cards

Relay Card

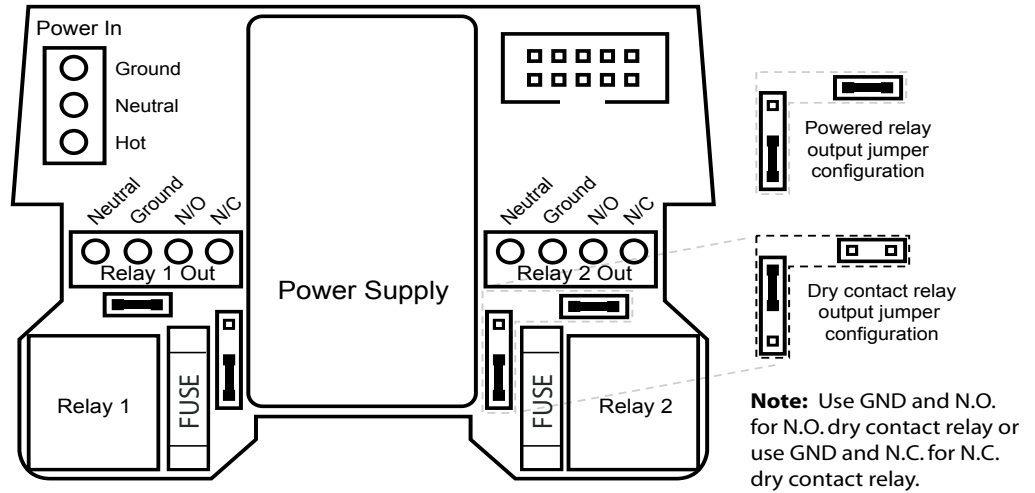

NanoTron-C & B2 Logic Card

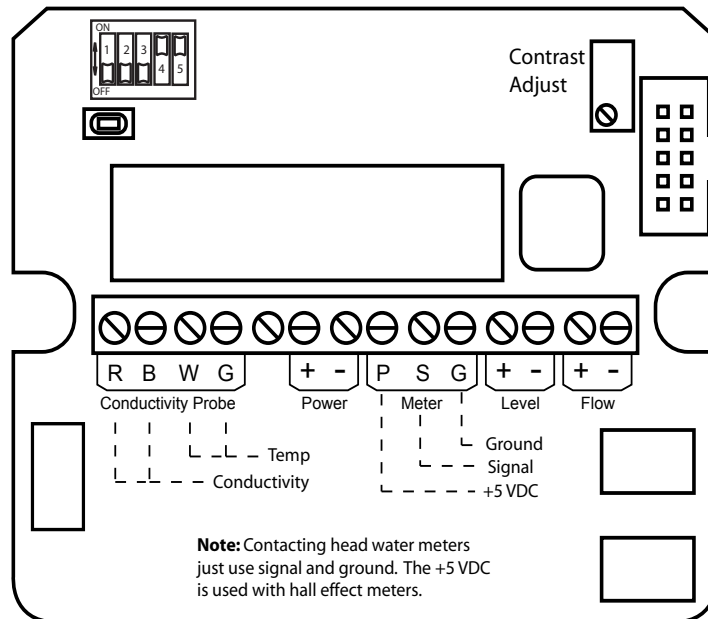

Switch #	Position	Function
1	OFF	Backlight normally off; flashes on w/ alarm
1	ON	Backlight normally on; flashes off w/ alarm
2	OFF	Normal Operation
2	ON	"Burn-in" Mode
3	OFF	Normal Operation
3	ON	Clear Memory (Resets to factory defaults)
4	OFF	"A" Range Temp Comp - 5k thermistor
4	ON	"B" Range Temp Comp - 30k thermistor
5	OFF	Set for 1x6 LCD (Normal)
5	ON	Set for 4x20 LCD (Debug @ Factory)

Note: Relay 1 is for Conductivity Bleed. Relay 2 is for Single Timer

Electrode Installation

Controllers may come configured for various circulating water systems. Listed below are instructions for cooling tower and boiler typical installations. Your specific installation requirements may differ but should conform to these instructions as much as possible for proper operation.

A. Cooling Tower

The standard probe(s) and/or flow assembly for cooling tower installations is constructed of schedule 80 PVC and supplied with 3/4" slip fittings for installing into a sample line. To insure proper operation the sample line must have a flow rate of 3-10 gpm. Inlet pressure must be higher than outlet pressure in order for water to flow past the electrode(s) to achieve the required rate. The probes are temperature compensated for increased accuracy.

NOTES:

1. Install an isolation valve on either side of the flow assembly so electrodes can be easily isolated for removal and cleaning.
2. A line strainer is recommended upstream from the probes to protect against fouling and damage.
3. Systems with a flow switch require 2-3 gpm flow rate to operate outputs.



WARNINGS:

1. Electrodes are O-ring sealed, which if damaged will cause a leak.
2. Do not allow pH sensor tips to dry out, damage will occur.
3. Do not exceed a water temperature range of 32°F to 140°F.
4. Do not exceed a maximum pressure of 150 psi.

Typical Cooling Tower Installation Diagram

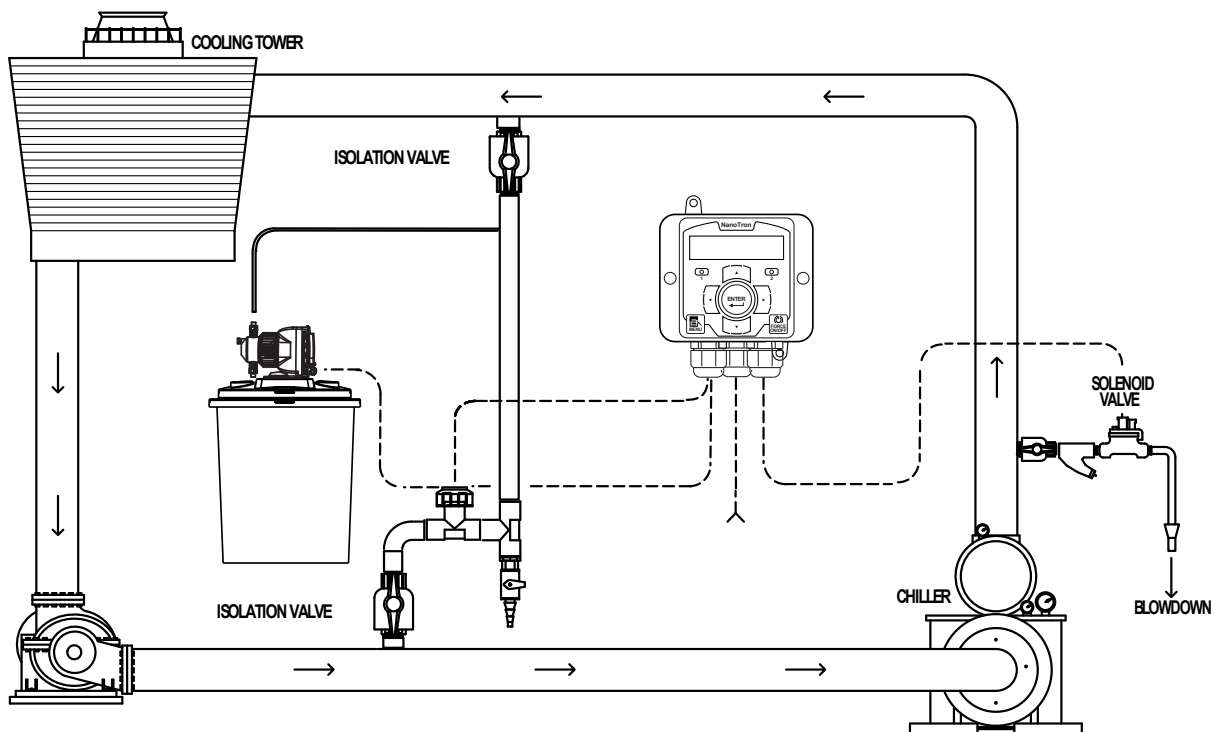

B. Boiler

Standard boiler electrodes have a MNPT stainless steel bushing and are supplied with a FNPT cross designed for mounting in the skimmer (surface) blowdown line. Sampling of the boiler's water can be achieved using one of two typical plumbing configurations (continuous sampling or timed and/or hold sampling). For a successful installation, it is critical to observe the recommended distances and pipe sizes provided in the installation drawings.

For best results, the electrode cross should be mounted in a 1" skimmer blowdown line within 4' of the boiler. Smaller line sizes and greater distances may affect the response time and accuracy of the electrode. A flow-throttling device down stream from the probe (within 24 inches) is required to ensure that the electrode is exposed to water and not steam. Properly installed and adjusted, this device will prevent flashing in the electrode chamber.

NOTES:

1. **Install a fully ported type valve between the electrode and the boiler. This allows the electrode to be isolated for removal and cleaning.**
2. **A flushing line and 1/4 turn type ball valve should be installed in the bottom of the cross to periodically "flush" sediment from the electrode chamber.**
3. **Make sure the alignment arrows on the probe end up parallel to the flow for best performance.**



WARNINGS:

1. **The probe must be fully immersed in the system water to read correctly. Steam flashing will result in incorrect readings.**
2. **Do not exceed a maximum water temperature of 436°F (224°C)**
3. **Do not exceed a maximum pressure of 350 psi (24.1 bar)**
4. **A throttling device must be installed down stream from the electrode.**

Boiler Conductivity Electrodes

BE-32

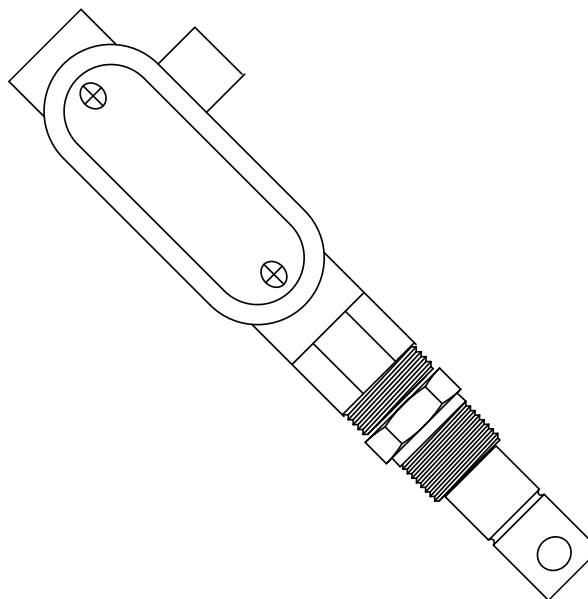

Wiring Note: BE-32 probes require a 2 conductor cable from controller to probe.

Typical Continuous Sampling Boiler Installation Diagrams

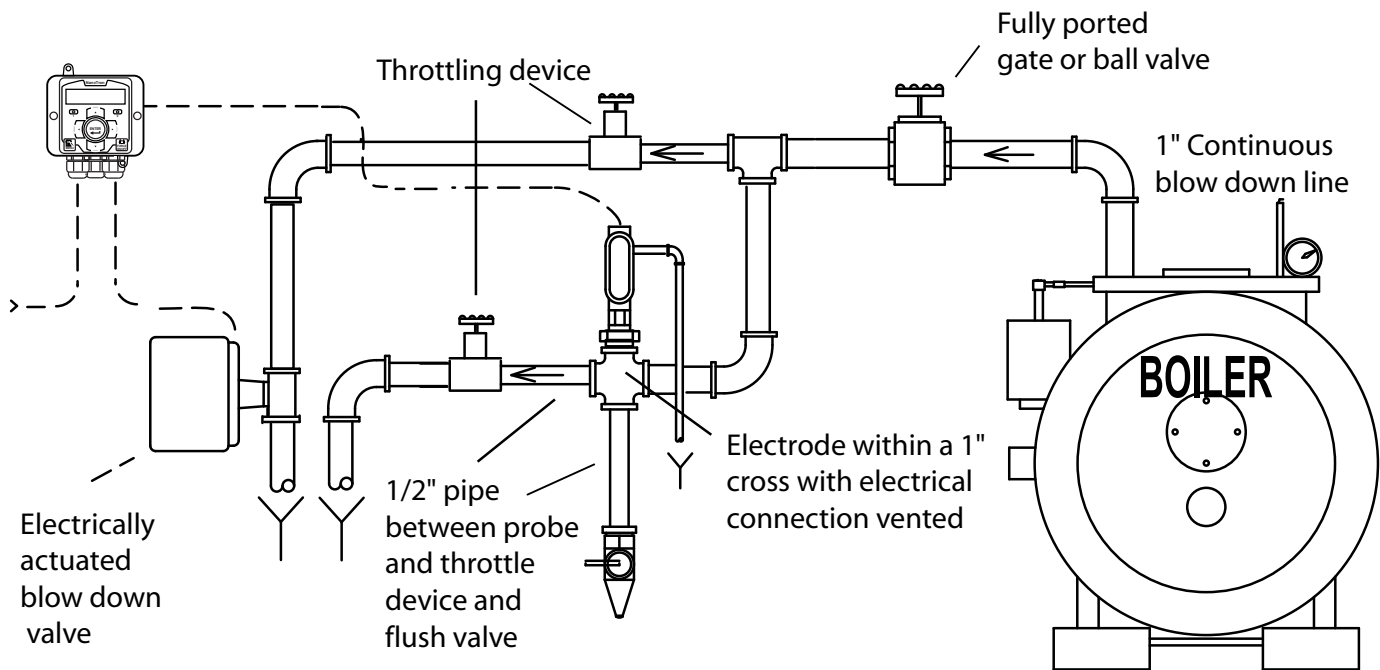

Warning - Do not use on bottom blowdown lines, only continuous or surface blowdown lines.

Typical Timed Sampling and Sample and Hold Boiler Installation

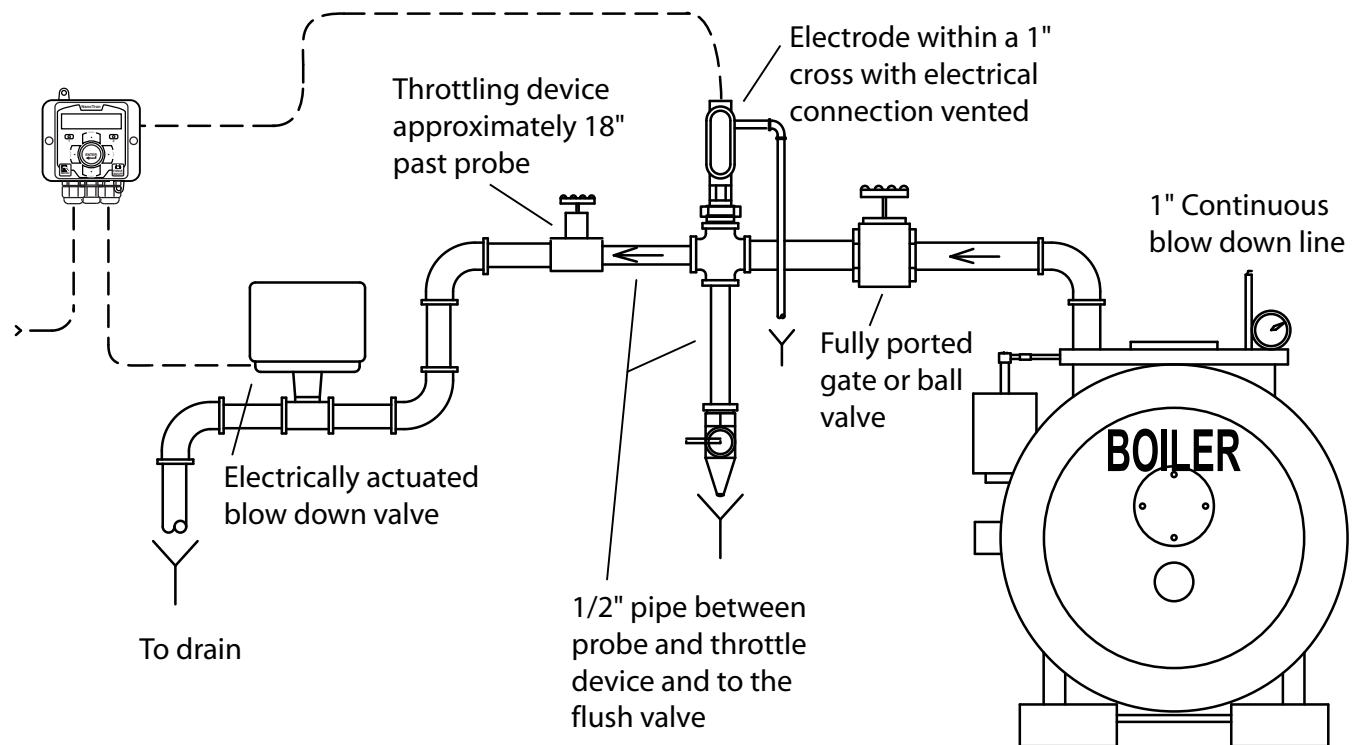

Warning - Do not use on bottom blowdown lines, only continuous or surface blowdown lines.

IV. Front Panel Description

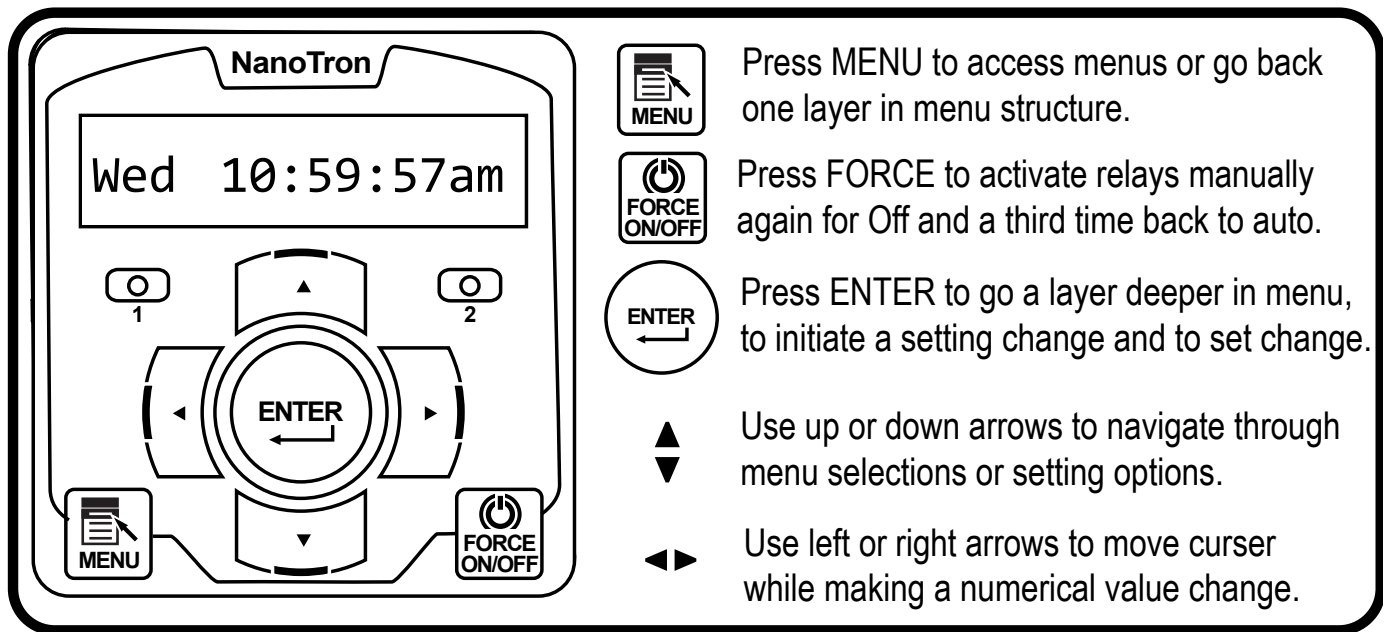

V. System Operation Overview

Description of Menus

NanoTron controllers have three modes of operation, Run, Menu and Force. All menus are circular. Pressing the DOWN key will display the next line of information on the display.

Run - This mode is for normal operation. The control relays will only be automatically active in this mode. In the Run mode, the display will read system values. If an alarm is present, the display flashes with the alarm status.

The Run menu will display values such as day, time, date and other values depending upon the features present on the unit. The unit will automatically return to the Run mode if no keys are pressed for three minutes.

Menu - This mode is used to make adjustments to settings and readings on the controller. To access the Menu mode from the run screen, press the Menu key. Use the up or down arrow to scroll through the various menus. When you want to access a specific menu, press the Enter key. Once you have entered a sub-menu you will be able to step through that menu's options with the up or down arrow key.

Force - Relays may be forced on or off for a user defined amount of time. Press the Force key to force relays on for the time configured in the Menu's force sub-menu. Press it a second time to force them off for the same amount of time. Press a third time to go back to automatic Run mode. Unit returns to the Run mode automatically when the force time has elapsed.

Conductivity Sampling Methods

- A. Continuous** - Typical for most tower applications. The controller is constantly reading the sensor and activating the bleed relay based on readings relationship to the set point, set point direction and differential. Example: A rising set point of 1500 and differential of 50 the bleed relay would activate when the conductivity rises above 1500 and stays on until the reading drops to 1450.
- B. Timed Sampling** - A sample timer allows the conductivity to be sampled at periodic intervals. Sample intervals are adjustable from 1 minute to 99 hours, 59 min. Sample duration (on-time) is adjustable from 1 second to 99 minutes, 59 seconds. If the reading is below the set point by the differential amount the bleed relay will be turned off at the end of the sample duration and the sample interval countdown reinitiated. If the reading is above the set point at the end of the sample method the bleed relay stays on until the reading drops by the differential amount.
- C. Sample and Hold** - Also uses a sample timer for periodic sampling intervals. The unit will sample for its duration then hold the blowdown valve closed for a settable period (hold time). The conductivity is checked at the end of the hold period, if additional blowdown is required the blowdown valve is held open for a preset amount of time (blowdown time). Then sample cycle is repeated until the reading is below the set point at the end of a hold cycle and the sample interval countdown reinitiated.

Note: Timed Sampling and Sample and Hold are typically used for boiler applications but Timed sampling can also be used on small towers. On these tower applications the probe is installed in the bleed line before the bleed valve.

Calibration Overview

The NanoTron controllers update the conductivity reading every two seconds with a running average. Nanotron controller's conductivity scale should be selected so that the conductivity setpoint is as close as possible to the middle of the scale. (See page 13 menu for setting scale).

Note: If a controller is using Timed Sampling or Sampling and Hold methods of control the conductivity reading shown in the RUN mode may not be a current reading. The controller will hold and display the conductivity value seen at the end of the last sample or hold duration. To see a current reading force on the bleed relay with either the Force button or via the Calibration menu.

- A. Continuous** - Calibrating continuous sampling units can be done at any time with the probe in a steady stream of water with no air or steam present.
- B. Timed Sampling** - While in the calibration menu there is a selection to force on the bleed relay. It will force it into the sample period. After 1-2 minutes verify that the reading is stable then enter the desired calibration value.
- C. Sample and Hold** - While in the calibration menu there is a selection to force on the bleed relay. It will force the unit into its sample and hold periods and calibration should be done during the hold after a fresh sample.

Notes:

1. If steam is flashing on boiler probes a stable reading will not be maintained and the controller will not track.
2. **If you change the conductivity scale in the Configure menu you MUST then go to Diagnostics and Reset the Cal then go to the Calibration menu and calibrate accordingly.**

VI. Maintenance

The only required maintenance for normal uninterrupted operation of your controller is cleaning of the electrode(s). After initial start up, it is a good idea to clean the electrode frequently until a schedule based on need has been developed. Since each application is unique, it is difficult to estimate the required frequency of cleaning. The first cleaning should take place after about one week of the system being on line.

To determine the required cleaning frequency, record the reading on the controller before the electrode is removed for cleaning. After cleaning, record the new reading. If a change is observed in the two readings, the electrode was dirty. The more significant the change, the dirtier the electrode. If no change occurs, cleaning needs to be done less often.

Conductivity Electrode Cleaning Procedure

1. Record the current conductivity reading.
2. Turn off water flow through the electrode loop, bleed pressure from the line and remove electrode.
3. Use a clean cloth and a mild cleaning solution to remove loose dirt etc., from the flat surface of the electrode.
4. If the electrode has deposits such as scale attached to the electrode surface a more aggressive cleaning approach will be needed. There are several ways to do this, the preferred method being the one that is easiest for the user.
 - a. Use a mild acid solution to dissolve deposits.
 - b. Lay a piece of sandpaper (200 grit or finer) on a flat surface such as a bench top. "Sand" electrode to remove stubborn deposits. (Do not wipe surface with your finger.) Oil from your skin will foul carbon tips.
5. Reinstall the electrode in the system. After the reading stabilizes, calibrate the unit to a reliable test reading.

Many times an electrode can appear to be clean, but the unit still cannot be calibrated. If this is the case, use one of the more aggressive electrode cleaning procedures listed in step 4 above. Recheck the calibration after completion of this procedure. If no change was observed in the reading, replace the electrode. If a change occurred but the unit still will not calibrate, repeat procedure as many times as necessary.

VII. Troubleshooting

The Advantage NanoTron controller is designed for many years of trouble free operation. Should a problem occur, refer to the following chart to help identify the problem. If replacement is required, follow the procedures listed in the Warranty and Factory Service portion of this manual.

SYMPTOM	POSSIBLE CAUSE	SOLUTION
False reading.....	Bad or dirty electrode	Clean, as needed
	Out of calibration	Calibrate unit
Will not calibrate	Dirty electrode	Clean electrode
	Faulty electrode	Replace electrode if needed
	Faulty wiring to electrode	Replace wiring if needed
No system power.....	Check power source	Plug into different receptacle
	Check fuse	Replace as needed
	Check connections	Make sure ribbon cables are secure
Pulse timer not activating	Check wiring	Repair as needed
	Check external device	Repair/replace as needed
Outputs not energized	No flow	Check sample line for clogged pipes or strainers
	Check fuse	Replace as needed

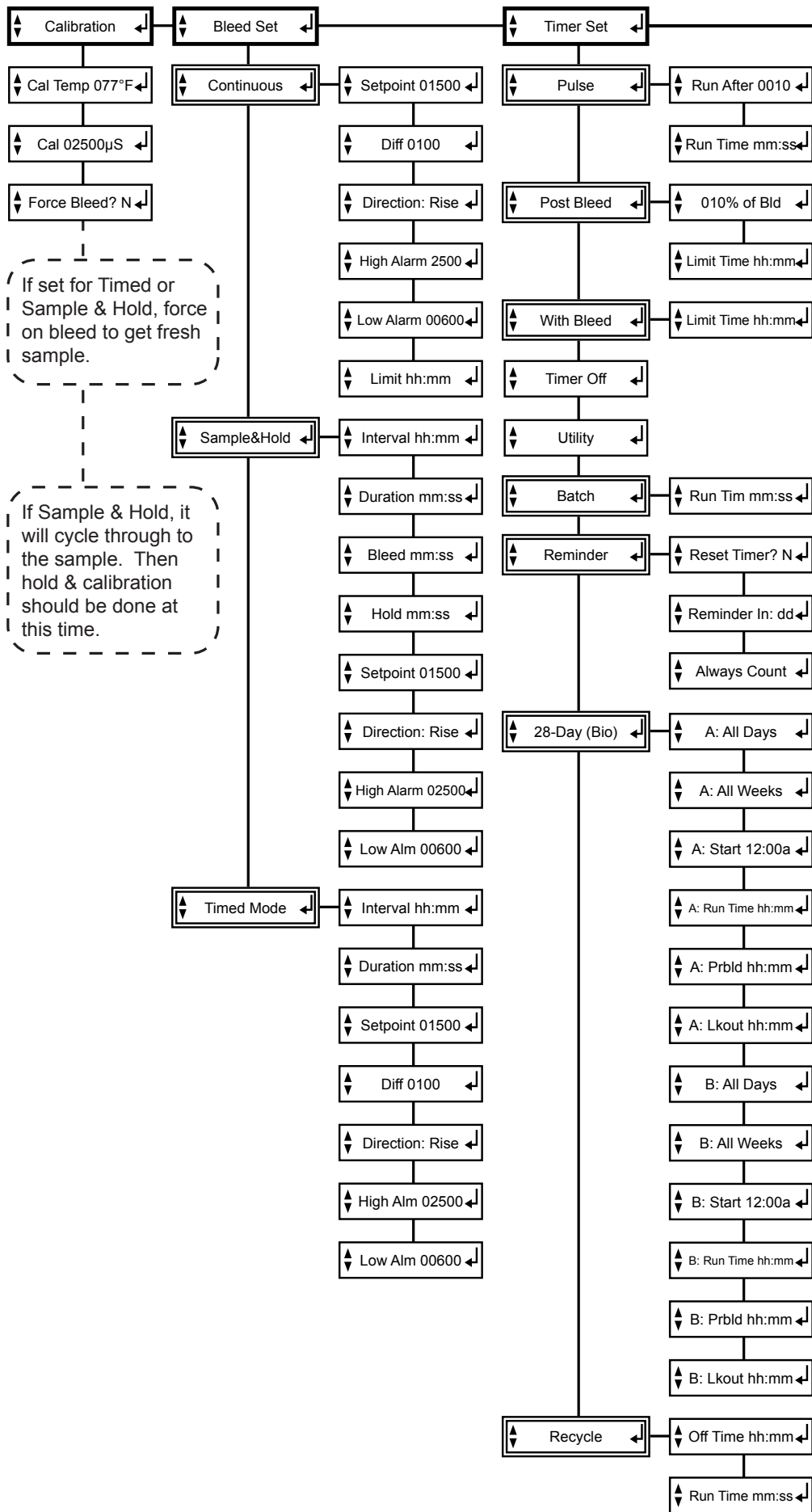

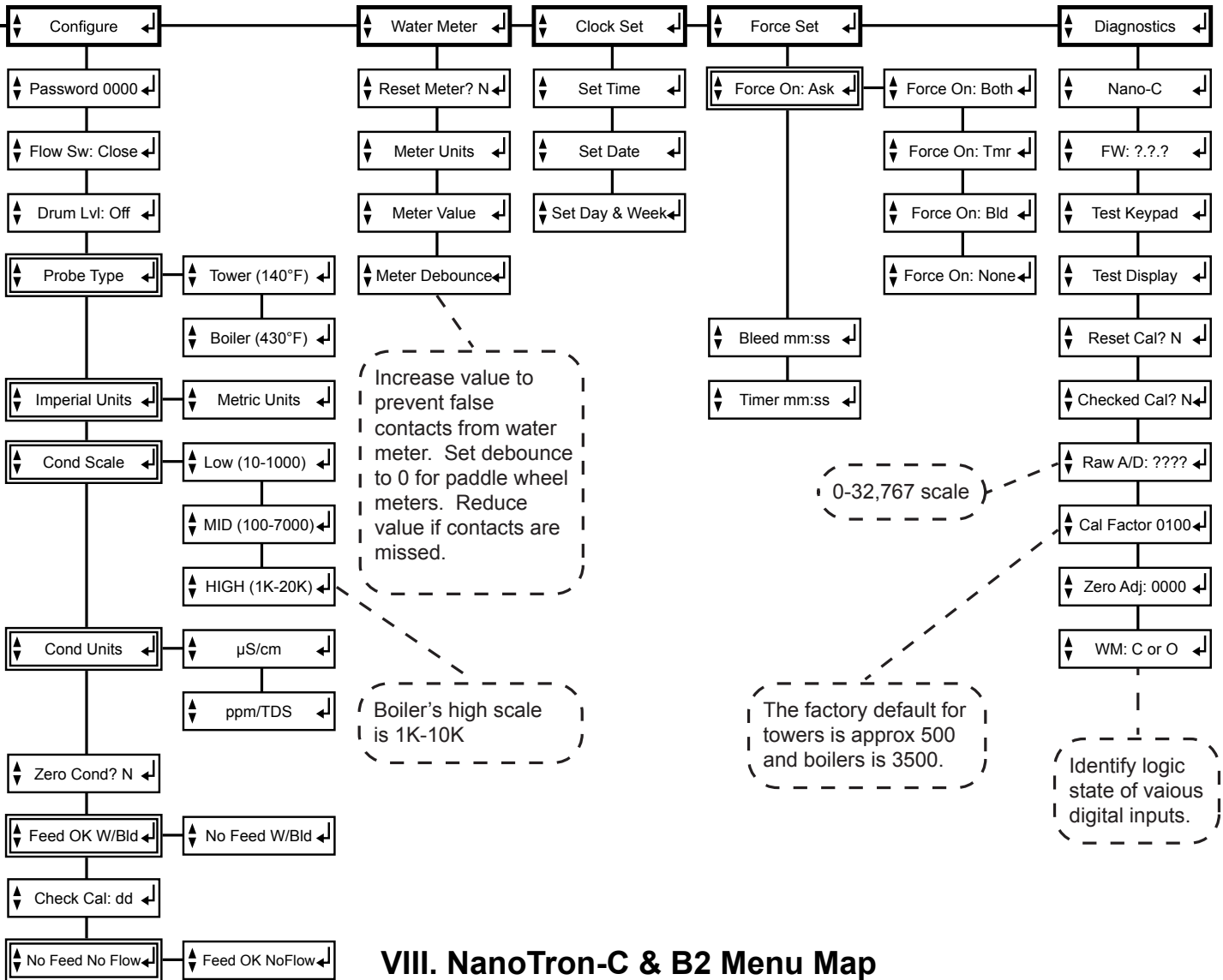

VIII. NanoTron-C & B2 Menu Map

NanoTron conductivity units have a main menu circle that includes:

- Calibration** - Calibrating the conductivity reading
- Bleed Set** - Setting the conductivity bleed set point, sample method and alarms
- Timer Set** - Select the timer type and run values
- Configure** - Password, flow switch direction, probe type, units of measure and more
- Water Meter** - Reset totalizer and setting contact value
- Clock Set** - Set time, date and week
- Force Set** - Set the force on time for manual relay activations
- Diagnostics** - Tests and calibration reset

IX. Manufacturer's Product Warranty

Advantage Controls warrants units of its manufacture to be free of defects in material or workmanship. Liability under this policy extends for 24 months from date of installation. Liability is limited to repair or replacement of any failed equipment or part proven defective in material or workmanship upon manufacturer's examination. Removal and installation costs are not included under this warranty. Manufacturer's liability shall never exceed the selling price of equipment or part in question.

Advantage disclaims all liability for damage caused by its products by improper installation, maintenance, use or attempts to operate products beyond their intended functionality, intentionally or otherwise, or any unauthorized repair. Advantage is not responsible for damages, injuries or expense incurred through the use of its products.

The above warranty is in lieu of other warranties, either expressed or implied. No agent of ours is authorized to provide any warranty other than the above.

30 Day Billing Memo Policy

Advantage Controls maintains a unique factory exchange program to ensure uninterrupted service with minimum downtime. If your unit malfunctions, call 1-800-743-7431, and provide our technician with Model and Serial Number information. If we are unable to diagnose and solve your problem over the phone, a fully warranted replacement unit will be shipped, usually within 48 hours, on a 30 Day Billing Memo.

This service requires a purchase order and the replacement unit is billed to your regular account for payment.

The replacement unit will be billed at current list price for that model less any applicable resale discount. Upon return of your old unit, credit will be issued to your account if the unit is in warranty. If the unit is out of warranty or the damage not covered, a partial credit will be applied based upon a prorated replacement price schedule dependent on the age of the unit. Any exchange covers only the controller or pump. Electrodes, liquid end components and other external accessories are not included.

FCC Warning

This equipment generates and uses radio frequency energy and if not installed and used properly, that is, in strict accordance with the manufacturer's instruction, may cause interference to radio communications. It has been type tested and found to comply with the limits for a class A computing device pursuant to subpart J of part 15 of FCC Rules, which are designed to provide reasonable protection against such interference when operated in a commercial or industrial environment. Operation of this equipment in a residential area is likely to cause interference in which case the user, at his own expense, will be required to take whatever measures necessary to correct the interference.

Get the Advantage in Water Treatment Equipment

Advantage Controls can give you the *Advantage* in products, knowledge and support on all of your water treatment equipment needs.

- Cooling Tower Controllers
- Boiler Blow Down Controllers
- Blow Down Valve Packages
- Solenoid Valves
- Water Meters
- Chemical Metering Pumps
- Corrosion Coupon Racks
- Chemical Solution Tanks
- Solid Feed Systems
- Feed Timers
- Filter Equipment
- Glycol Feed Systems
- Pre Fabricated Systems

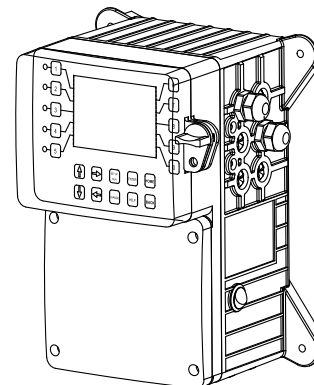
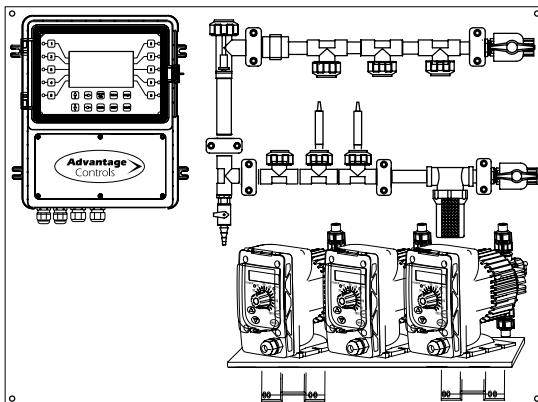
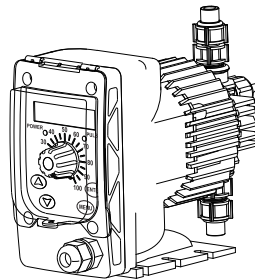
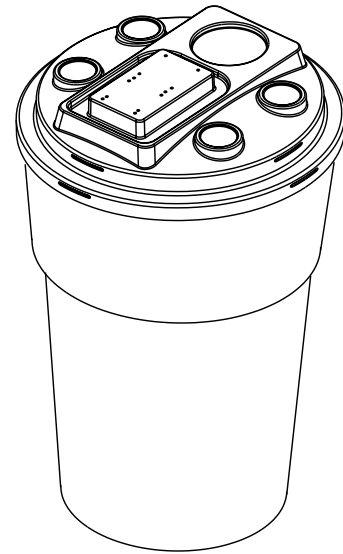
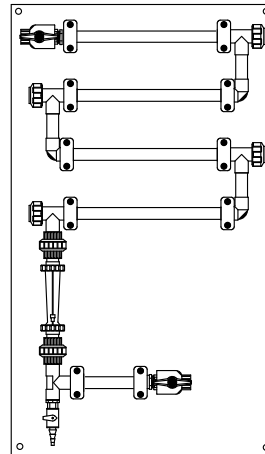
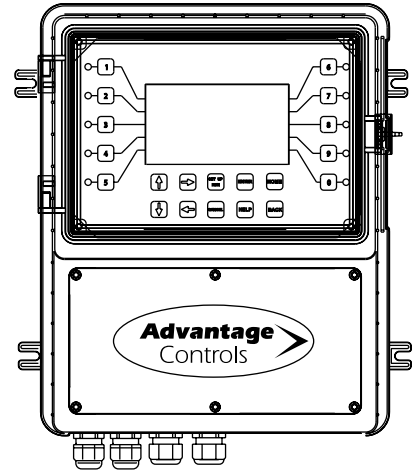
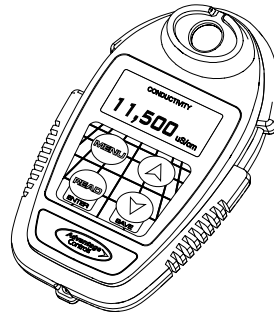

Get the Advantage

