U1000-U

Ultrasonic Flowmeter

(Universal)

User Manual



Micronics Ltd, Knaves Beech Business Centre, Davies Way, Loudwater,
High Wycombe, Bucks HP10 9QR

Telephone: +44(0)1628 810456

Facsimile: +44(0)1628 531540

E-mail: sales@micronicsltd.co.uk

www.micronicsflowmeters.com

Table of Contents

1	General Description	3
2	Quick start procedure	4
3	How does it work?	5
4	User interface.....	6
4.1	Key switches	6
5	Installing the U1000-U	7
5.1	Preparation.....	8
5.2	Sensor separation.....	8
5.3	Adaptors for small pipes	10
5.4	Attaching the U1000 to the pipe.....	11
5.5	U1000-U interface cable	12
5.6	Connecting the U1000-U to the Supply.....	12
5.7	Pulse Output connection.....	13
5.8	Current Output (If fitted).....	13
5.9	Cable Screen	13
6	Powering up for the first time.....	14
6.1	How to enter the Pipe ID.....	15
6.2	Pulse output	16
6.2.1	Volumetric mode	16
6.2.2	Frequency mode.....	16
6.2.3	Low Flow Alarm	16
6.2.4	Loss of Flow Reading Alarm	16
6.3	4-20mA Current output (If fitted).....	16
7	Subsequent Power-ON Sequence	17
8	Password Controlled Menus	17
8.1	General procedure for changing menu settings.....	17
8.1.1	Selection menus	17
8.1.2	Data entry menus	18
8.2	User Password controlled menu structure	18
9	Diagnostics Menu.....	23
10	Relocation of guide rail	24
11	Appendix I – U1000-U Specification	25
12	Appendix II – Default values	26
13	Appendix III – Error and Warning Messages.....	27
13	Declaration of Conformity	29

1 General Description

- Fixed installation, clamp-on flowmeter
- Easy to install
- Requires the minimum of information to be entered by the user
- Both the electronics and guide rail housings form an integral unit
- Simple attachment to the pipe using the supplied jubilee clips.
- Power to the unit is provided by an external 12 - 24V ac/dc power supply.
- Operates on steel, copper and plastic pipes with ID's in the range 20mm (0.8") to 110mm (4.3") and a maximum wall thickness of 9mm for metal pipes and 10.5mm for plastic.
- Compact, rugged and reliable, the U1000-U has been designed to provide sustained performance in industrial environments.

U1000-U standard features include:

- 2 line x 16 character LCD with backlight
- 4-key keypad
- Isolated pulse output
- Simplified guide rail and transducer assembly
- Continuous signal monitoring
- Password protected menu operation for secure use
- Operates from external 12 to 24Vac or dc power supplies
- Small pipe adaptors

Optional features

- 4-20mA current output

Typical applications

- Hot water metering and flow measurement
- Flow measurement for Heat Metering
- Chilled water metering and flow measurement
- Potable water metering and flow measurement
- Process water metering and flow measurement
- Ultra-pure water metering and flow measurement.

2 Quick start procedure

The following procedure details the steps required to set up the heat meter. See the sections referred to if you are unsure about how to install the instrument.

1. Establish a suitable location for the flow meter on a straight length of pipe clear of bends and valves or similar obstructions. (See Sections 5 and 5.1)
2. Determine the pipe internal diameter and material.
3. Either use the table in the manual, or power up the instrument to determine the correct separation code. (See Sections 5.2 or 6)
4. Set the sensors to the correct separation by adjusting the sensor holding screws so the sensor can slide in the slot. (See Section 5.2)
5. Select any adaptors needed for pipes with an **outside** diameter of less than 60mm, **inside** diameter will typically be less than 50mm. (See Section 5.4)
6. Grease the sensors and mount the guide rail on the pipe using the banding provided, then remove the sensor holding screws. (See Section 5.3)
7. Wire the electronics up to a 12 to 24V ac or dc power supply via the Blue and Brown wires. (See Section 5.7)
8. Plug in the flow sensors and clip the electronics assembly on to the guide rail.
9. Power up the instrument and check that flow readings can be obtained (See Sections 6 and 7.1)
10. Once good readings have been obtained any further changes, such as selecting different units, can be made via the User Menu. (See Section 8)

3 How does it work?

The U1000-U is a clamp-on, ultrasonic flowmeter that uses a multiple slope transit time algorithm to provide accurate flow measurements.

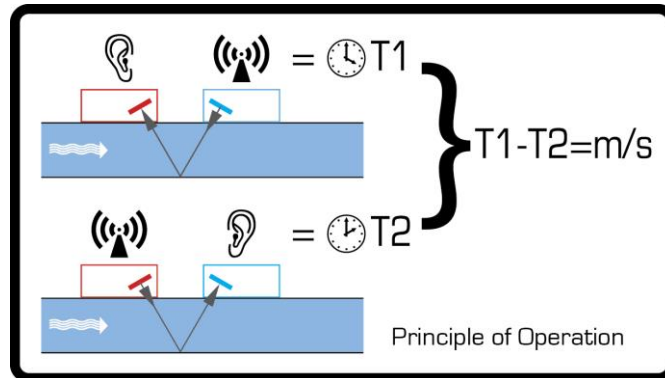

Figure 1 Principle of Transit-Time operation

An ultrasonic beam of a given frequency is generated by applying a repetitive voltage pulse to the transducer crystals. This transmission goes first from the Downstream transducer to the Upstream transducer (red) as shown in the upper half of Figure 1. The transmission is then made in the reverse direction, being sent from the Upstream transducer (red) to the Downstream transducer (blue) as shown in the lower half of Figure 1. The speed at which the ultrasound is transmitted through the liquid is accelerated slightly by the velocity of the liquid through the pipe. The subsequent time difference $T1 - T2$ is directly proportional to the liquid flow velocity.

4 User interface

Figure 2 illustrates the U1000-U user interface comprising:-

- One 2 line x 16 character LCD with backlight
- Four tactile key switches
- Two LED's



Figure 2 U1000-U User Interface

4.1 Key switches



Selection key. Allows the user to select between options on the display.



Used to increment the value of each digit in numeric entry fields.



Used to decrement the value of each digit in numeric entry fields.



Used to enter the selection displayed or terminate the data entry. Pressing this key will take the user to another menu or to the Flow Reading screen.



4-20mA LED is illuminated when the 4-20mA output is ON



Pulse LED is illuminated when the Pulse output or Frequency output are enabled, and then flashes to indicated active pulse activity. It is also illuminated if an alarm is enabled and active.

5 Installing the U1000-U

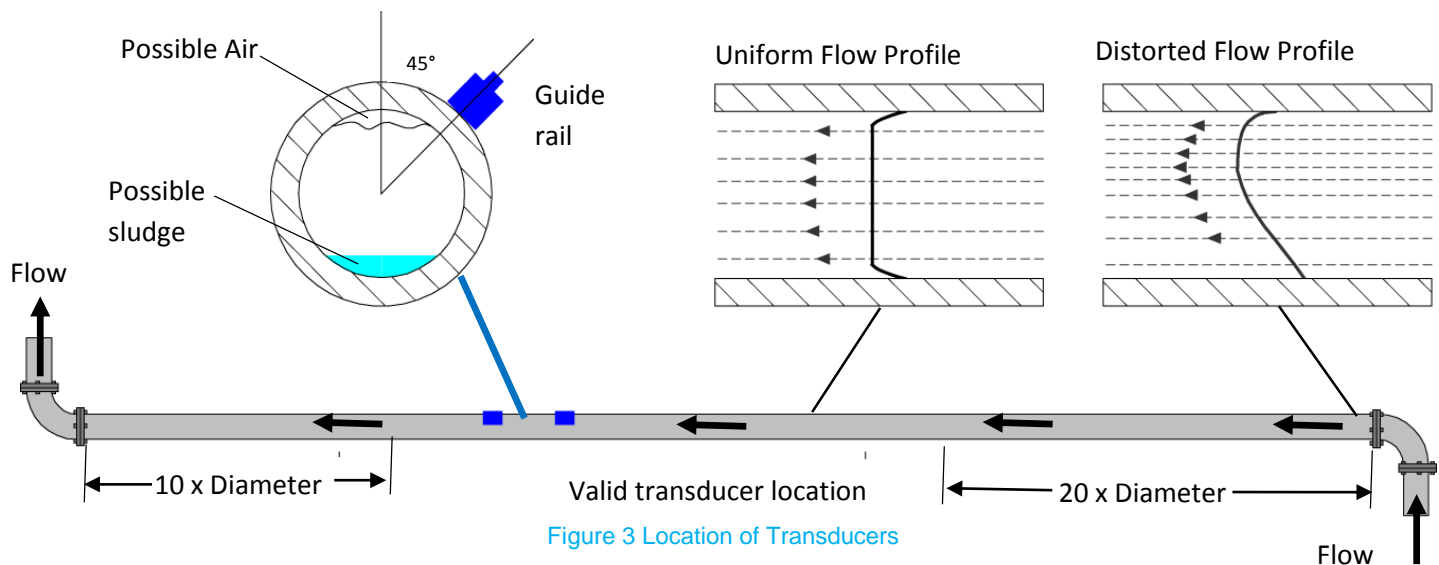

Figure 3 Location of Transducers

In many applications an even flow velocity profile over a full 360° is unattainable due, for example, to the presence of air turbulence at the top of the flow and also possibly sludge at the bottom of the pipe. Experience has shown that the most consistently accurate results are achieved when the transducer guide rails are mounted at 45° with respect to the top of the pipe.

The U1000-U equipment expects a uniform flow profile as a distorted flow will produce unpredictable measurement errors. Flow profile distortions can result from upstream disturbance such as bends, tees, valves, pumps and other similar obstructions. To ensure a uniform profile the transducers must be mounted far enough away from any cause of distortion such that it no longer has an effect.

To obtain the most accurate results the condition of both the liquid and the pipe must be suitable to allow ultrasound transmission along the predetermined path. It is important that liquid flows uniformly within the length of pipe being monitored, and that the flow profile is not distorted by any upstream or downstream obstructions. This is best achieved by ensuring there is a straight length of pipe upstream of the transducers of at least 20 times the pipe diameter, and 10 times the pipe diameter on the downstream side, as shown in Figure 3. Flow Measurements can be made on shorter lengths of straight pipe, down to 10 diameters upstream and 5 diameters downstream, but when the transducers are mounted this close to any obstruction the resulting errors can be unpredictable.

Key Point: Do not expect to obtain accurate results if the transducers are positioned close to any obstruction that distorts the uniformity of the flow profile.

Micronics Ltd accepts no responsibility or liability if product has not been installed in accordance with the installation instructions applicable to the product.

5.1 Preparation

1. Before attaching the transducers first ensure that the proposed location satisfies the distance requirements shown in [Figure 3](#) otherwise the resulting accuracy of the flow readings may be affected.
2. Prepare the pipe by degreasing it and removing any loose material or flaking paint in order to obtain the best possible surface. A smooth contact between pipe surface and the face of the transducers is an important factor in achieving a good ultrasound signal strength and therefore maximum accuracy.

5.2 Sensor separation

The sensor must be positioned at the correct distance for the pipe size and type they will be used on. The table below gives the typical separation code for a given pipe material and inside diameter, based on a 4mm wall thickness. If the wall thickness is significantly different from this value then the separation may need to be one code higher or lower. The instrument displays the required separation after the pipe internal diameter and material are entered.

Pipe ID range

Separation	Pipe material	
	Plastic and Copper	Steel
B1	20-24	---
A2	25-30	20-22
C1	31-36	23-28
B2	37-42	29-34
A3	43-48	35-40
C2	49-54	41-46
B3	55-60	47-52
D2	61-65	53-58
C3	66-71	59-64
B4	72-77	65-70
D3	78-83	71-76
C4	84-89	77-82
E3	90-95	83-88
D4	96-101	89-94
F3	102-107	95-100
E4	108-110	101-106
D5	---	107-110

Figure 4 Separation Table

The diagram below shows how to adjust the separation of the sensors

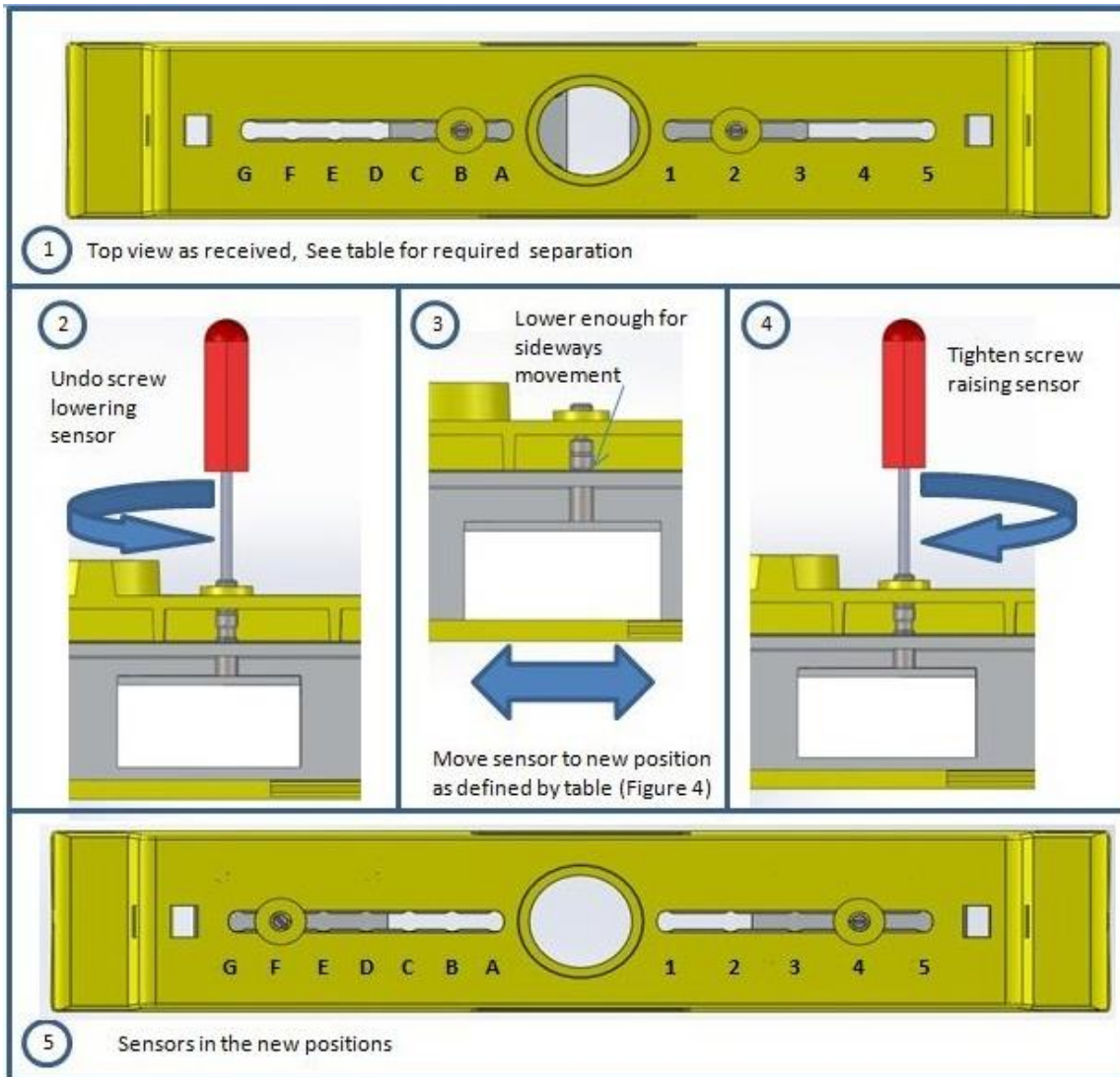

Figure 5 Separation Setting

5.3 Adaptors for small pipes

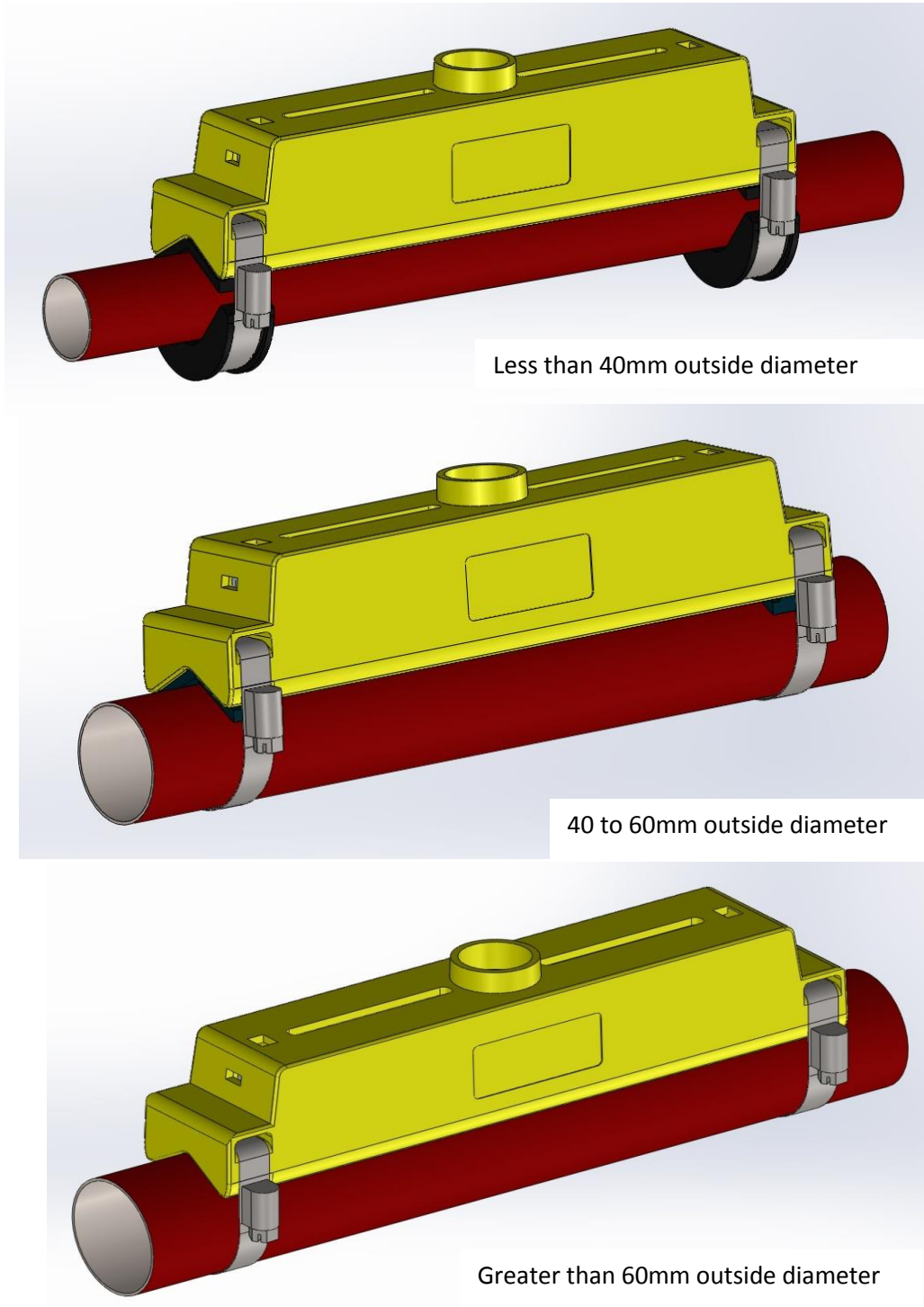
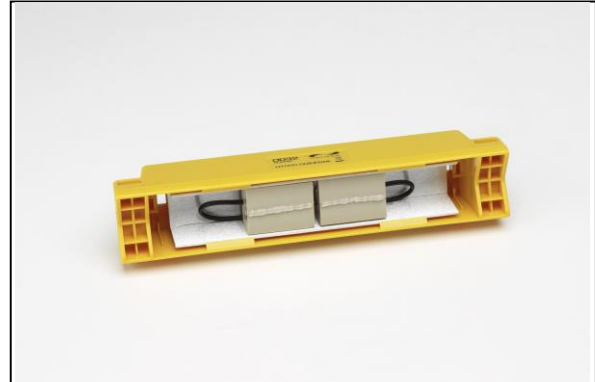
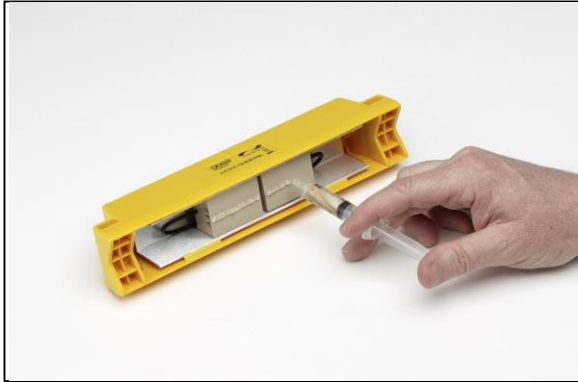

Figure 6 Pipe Adaptors

Adaptors are supplied for use on small pipes. The diagrams above show how these are fitted around the pipe. The top pipe adaptor clips into the ends of the guide rail.

5.4 Attaching the U1000 to the pipe

Follow the four steps shown in Figure 7 below to attach the U1000 to the pipe.



The grease provided in the syringe is applied to the centre of the sensors as shown above.



Clamp guide rail and sensor assembly to pipe, using the supplied banding, and release sensor locking screws.



Connect power and sensors to the electronics assembly. Sensor leads can be connected either way round.



Click electronic assembly onto guide rails and sensor assembly

[Figure 7 simple steps to attaching the U1000 on the pipe](#)

The locking screws and washers should be kept in case it is necessary to change the location of the guide rail and sensors. See the relocation section for the procedure to do this.

5.5 U1000-U interface cable

The U1000-U interface cable supplied is a 6-core cable and is shown in Figure 8.

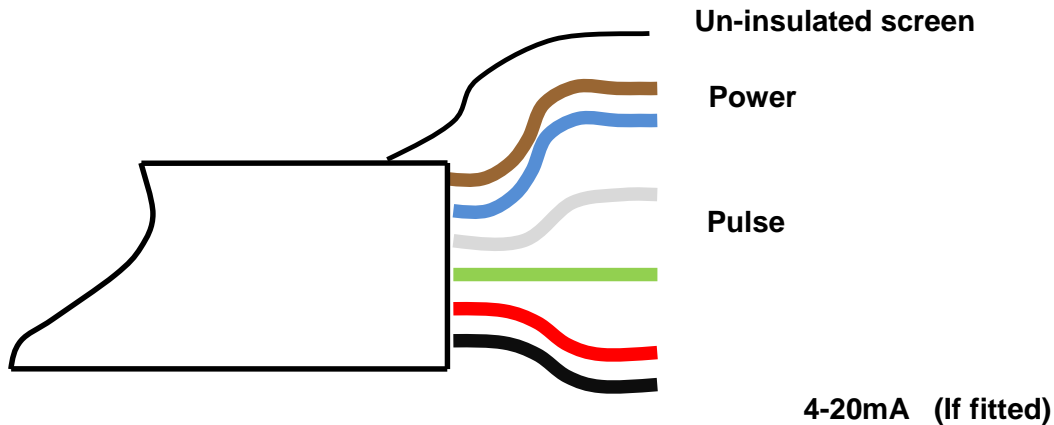

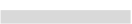





Figure 8. U1000-U Interface Cable

The polarity of the wires is as follows:

	12/24V Input
	12/24V Return
	Pulse Output
	Pulse Return
	4-20mA Output (+) (If fitted)
	4-20mA Return (-) (If fitted)

The un-insulated wire is the connection to the screen of the cable and should be earthed for full immunity to electrical noise.

5.6 Connecting the U1000-U to the Supply

The U1000-U will operate within the voltage range 12 - 24V ac/dc. Connect the external power supply to the Brown and Blue wires of the six core cable. For full compliance with EMC regulation a 12V supply is recommended for domestic and light industrial applications.

5.7 Pulse Output connection

The isolated pulse output is provided by a SPNO MOSFET Relay which has a maximum load current of 500mA and maximum load voltage of 48V AC. The relay also provides 2500V isolation. The pulse output is available at the White and Green wires. Electrically this is a volt free contact closure.

5.8 Current Output (If fitted)

The isolated 4-20mA is a current source and can drive into a maximum load of 620Ω.

The 4-20mA current output is available at the Red and Black wires. The polarities are shown in Figure 8.

The alarm current due to a flow outside the range specified or due to a loss of signal is set at 3.5mA.

5.9 Cable Screen

For full immunity to electrical interference the screen of the cable should be connected to Earth.

6 Powering up for the first time

Powering up for the first time will initiate the sequence shown in Figure 9:

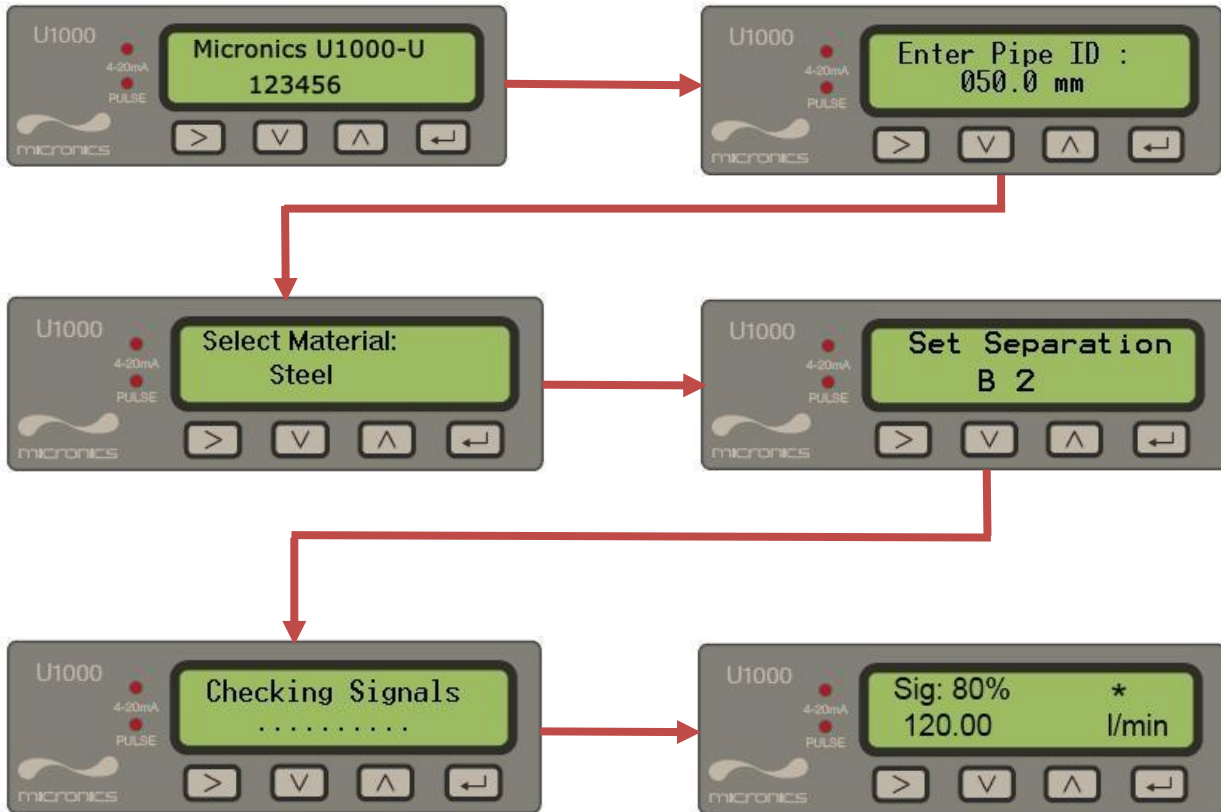

Figure 9 Initial power up screens

1. The start-up screen is displayed for 5 seconds
2. The user enters the pipe ID and then the material by scrolling through the available list. (Refer to section 5.1)
3. The U1000-U checks for a valid signal
4. If a valid signal is found, signal strength and flow magnitude are displayed. The signal strength should be at least 40% for reliable operation. The direction of flow when powered up will be set as that for positive flow. The current output and pulse output will relate to the flow in this direction. If the flow is reversed then the flow rate will still be displayed but the activity indication will change from an asterisk to an exclamation mark. No pulses will be generated, and the current will go to the 3.5mA alarm state if the flow is reversed.

If the flow value is displayed as “-----” this indicates that there is no usable signal from the sensors. The cause of this could be incorrect pipe data, no grease on the sensors, sensor not in contact with the pipe or very poor surface conditions on the inside of the pipe.

6.1 How to enter the Pipe ID

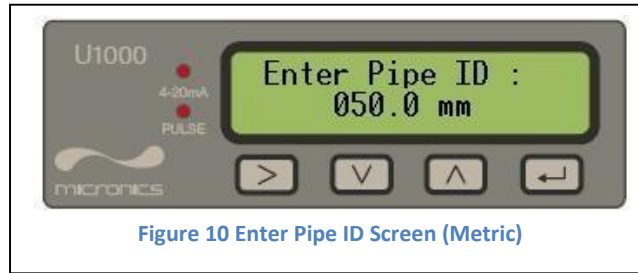

Figure 10 shows the Enter Pipe ID screen after an initial power up.



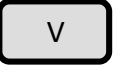

Initially, the hundreds unit (050.0) will blink.

Press the  key to increment the hundreds digit (050.0) in the sequence 0, 1. Press once to increment digit, or hold key down to automatically toggle between 0 and 1.

Press the  key to decrement the hundreds digit in the sequence 1, 0. Press once to decrement digit, or hold key down to automatically toggle between 1 and 0.

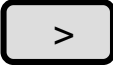

Press the  key to move to the tens digit (050.0). The tens digit should now blink. Increment the tens digit in the sequence 0,1,2,3,4,5,6,7,8,9,0 using the  key. Press once to increment digit or hold down to scroll through the numeric sequence. Decrement the tens digit in the sequence 9,8,7,6,5,4,3,2,1,0,9 using the  key. Press once to increment digit or hold down to scroll through the numeric sequence.

Press the  key to move to the units digit (050.0). The units digit should now blink. Increment or decrement the units digit in an identical manner to the tens digit described above.

Press the  key to move to the decimal digit (050.0). The decimal digit should now blink. Increment or decrement the decimal digit in an identical manner to the tens digit described above.

Press the  key to enter the Pipe ID numerical value, and move to the next screen

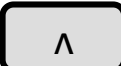
Pipe material
Steel

Use  and  keys to scroll through the pipe materials and then press

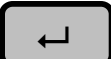
 To select the material and complete the setup procedure.

If any of the parameters need to be changed from the default values, for example different units are required, and then the menu system must be activated via the password (see section 7).

6.2 Pulse output

Pulse output can be set up to operate one of four modes, namely volumetric, frequency, Low Flow Alarm and Loss of Flow Reading Alarm.

6.2.1 Volumetric mode

In Volumetric mode, each pulse output represents a measured volume of 10 litres (default value). In Volumetric mode, with the Vol per Pulse set to 1 and the pulse width set to 25ms, the maximum number of pulses that can be output (without storage) is $1/(0.025*2) = 20$ pulses per second. If the flow rate in the pipe is such that more than 20 pulses per second are generated, a Pulse Overflow error may eventually occur if the stored number of pulses exceeds 1000. To avoid this, set the Vol per Pulse to 10 litres.

6.2.2 Frequency mode

In Frequency mode, the pulse output frequency is proportional to the flow rate within a specified frequency range of 0 – 200Hz. The units of the flow rate are fixed as litres per second.

6.2.3 Low Flow Alarm

The output will go to low resistance when the flow is below a programmed value, in the range 0 to 9999, in the units selected by the Setup menu. The Pulse LED will indicate the state of the alarm, if lit then the alarm is on.

6.2.4 Loss of Flow Reading Alarm

If the flow reading is lost, as indicated by the flow rate being displayed as “----”, then the output will go to low resistance. The Pulse LED will indicate the state of the alarm, if lit then the alarm is on.

6.3 4-20mA Current output (If fitted)

The default 4-20mA output setting is ON, and the 4-20mA LED on the keypad will be illuminated. The default flow for 20mA output will be automatically set depending on the pipe size. The default flow for 4mA is 0. This can be changed, see section 7.

If the flow reading is greater than that set as the 20mA value, or there is negative, flow, or no flow signal can be detected, then an alarm current of 3.5mA will generated.

Note: The 4-20mA current output is factory calibrated.

7 Subsequent Power-ON Sequence



If the power supply is cycled OFF then ON after the pipe ID has been entered, all subsequent start-ups will use the same configuration as was previously entered. If the configuration needs to be changed for any reason, the user can make use of the password-controlled menu as described in section 7.

8 Password Controlled Menus

The password controlled menu allows the user some flexibility to change the default settings:

User Password (71360):

- Change the dimensions from mm to inches or vice-versa.
- Change from Flow to Velocity Measurement
- Change the system units litres/m³ or Impgal/USgal
- Change the flow units l/s, l/min or gal/s, gal/min or USgals/s, USgals/min
- Change the default value for Flow at Maximum Current
- Change the default setting for Flow at Minimum Current
- Change the Pulse Output type
- Change the Pulse output parameters

Press the  key to get to the screen prompting for the password, which is entered using the method shown in 7.1.2. To exit the password controlled menu navigate to the Exit screen and press the  key. If you wish to abandon entering the password then wait until the display returns to the flow reading screen.

8.1 General procedure for changing menu settings

8.1.1 Selection menus

When a password controlled menu is selected the procedure for changing the default setting is the same for all menus. For example, consider the Flow Units menu shown in Figure 11.

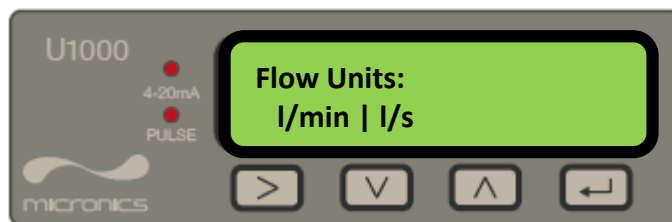



Figure 11 Flow Units menu

The default value 'l/min' will blink to indicate that this is the current setting. To change to 'l/s', press the  key. Now the 'l/s' units will blink to indicate that this is now the selected units. Press the  key to confirm the change.

8.1.2 Data entry menus

Menus containing a numeric value can be altered using the following procedure. For example, consider changing the Flow at maximum current from the default setting 1000 litres as indicated in Figure 12 to 1258 litres.

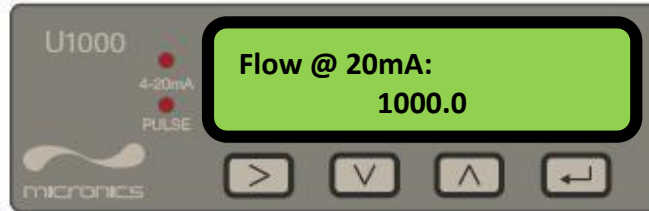

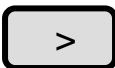







Figure 12 Example of a Data entry screen

- Press the  key twice to select the hundreds unit (1000.0) which will now blink
- Press the  key twice to increment the hundreds unit from 0 to 2 (1200.0)
- Press the  key once to select the tens unit (1200.0) which will now blink
- Press the  key five times to increment the hundreds unit from 0 to 5 (1250.0)
- Press the  key once to select units (1250.0) which will now blink
- Press the  key twice to decrement the units from 0 to 8 (1258.0)
- Press the  key to confirm the change

All numeric data menus can be changed in this way.

8.2 User Password controlled menu structure

Ensure that the instrument is in Flow Reading mode then press the  key to go to the user password menu. Enter 71360 using the procedure explained in section 7.1.2 to enter the password.

The flow chart shown in Figure 13 shows the user password menu structure. To skip over any menu item that should remain unchanged, simply press the  key.

71360 MENU

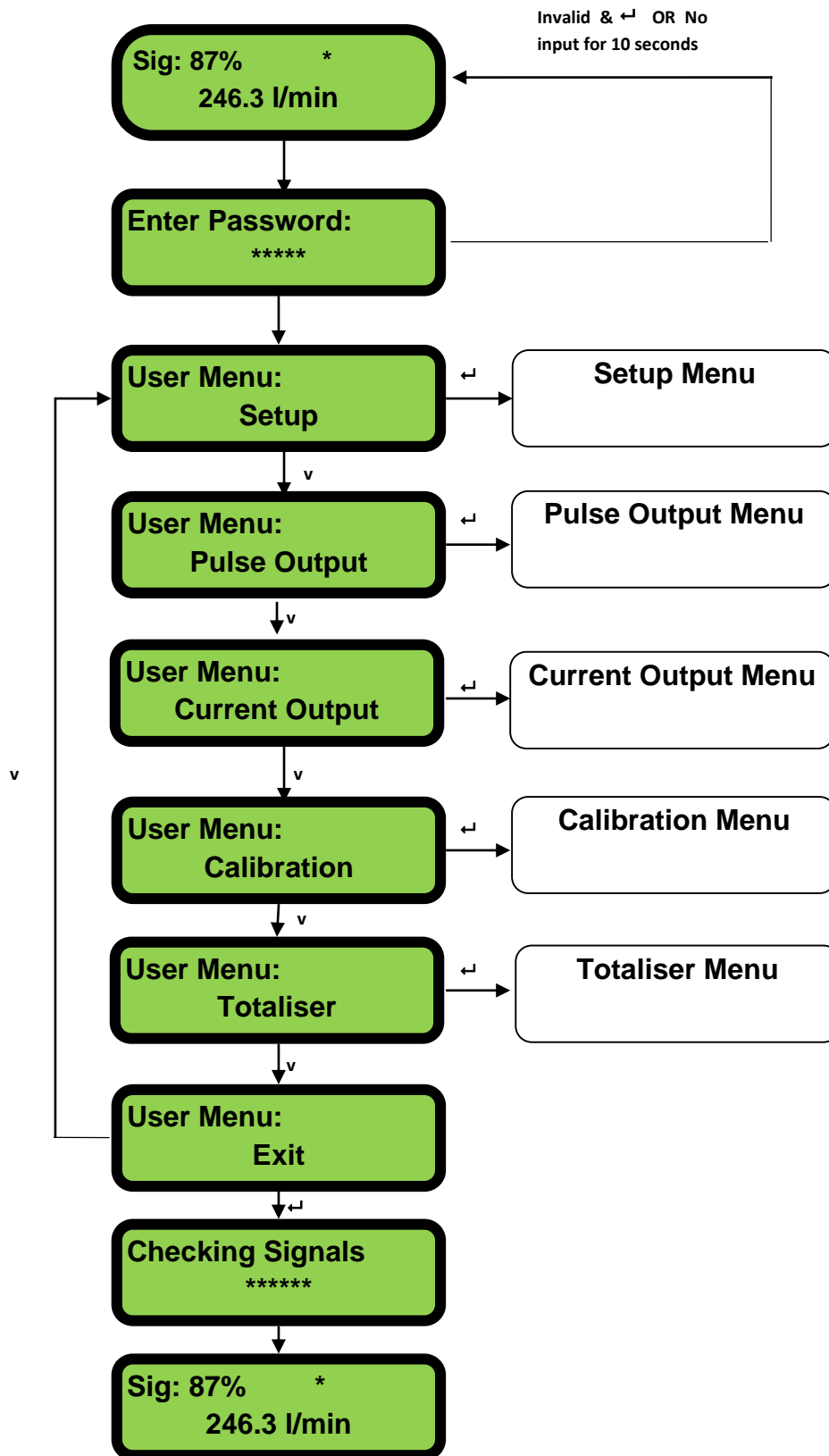

Figure 13 Main Menu

SETUP MENU

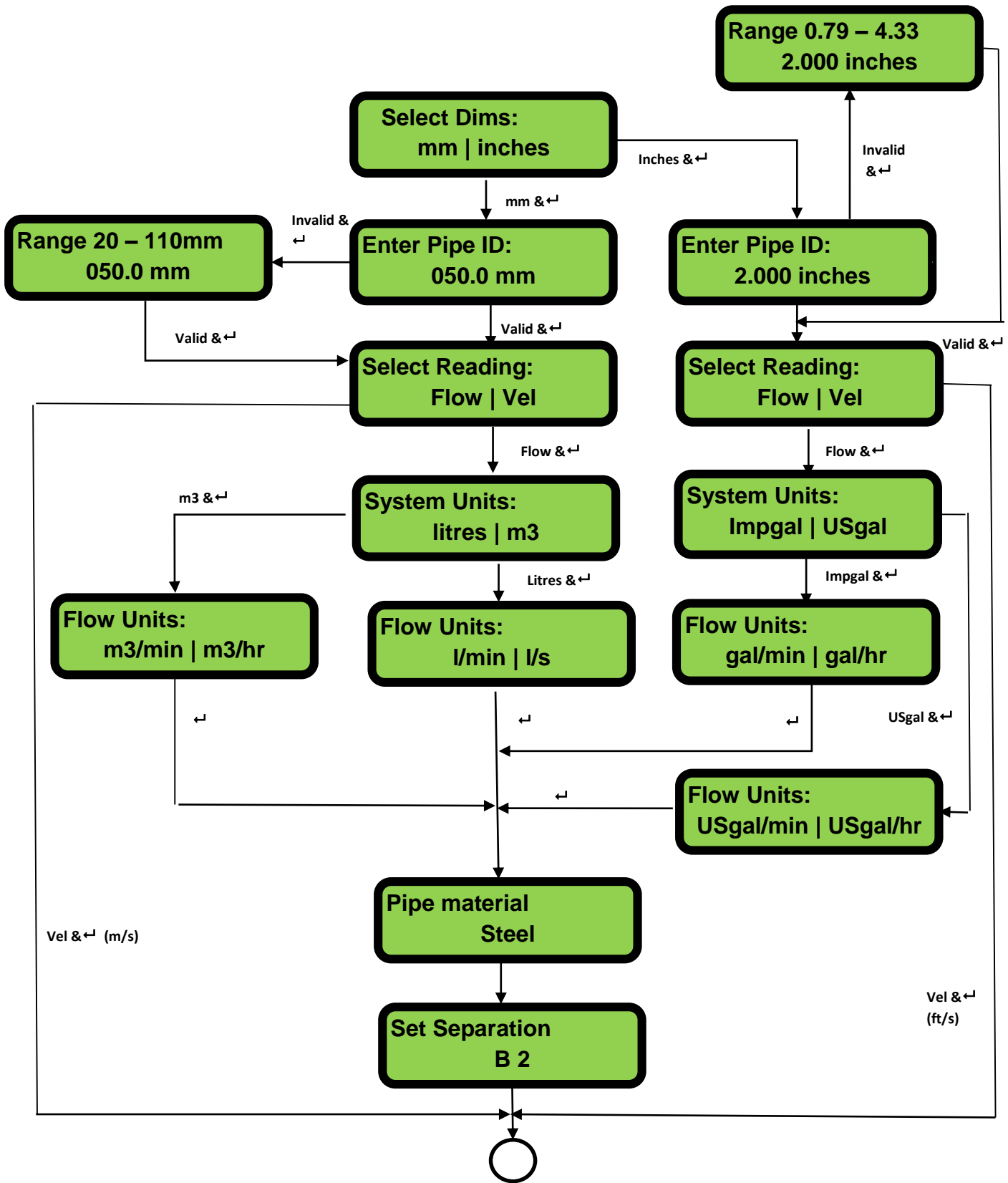
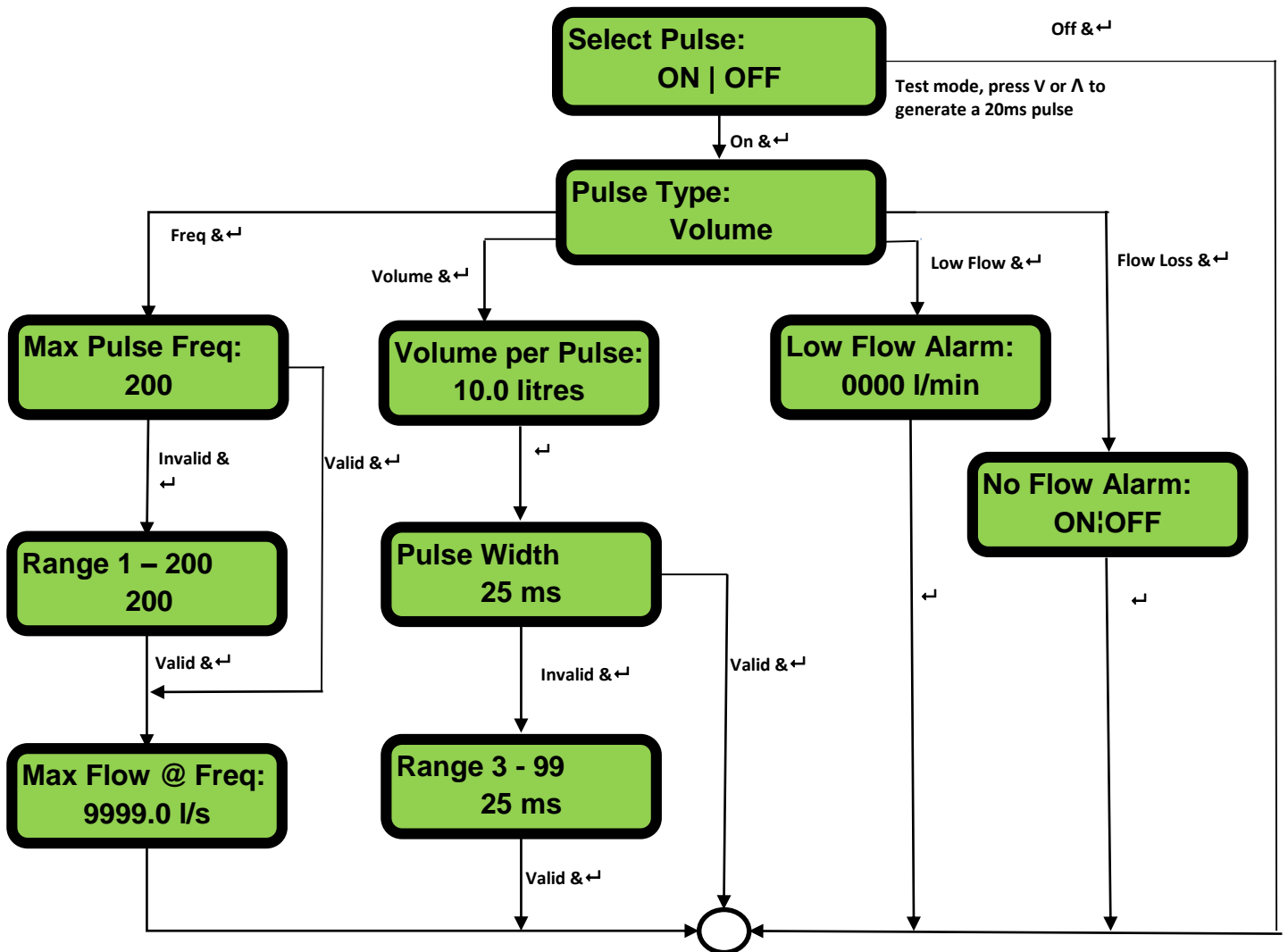

Figure 14 Setup Menu

PULSE OUTPUT MENU



TOTALISER MENU

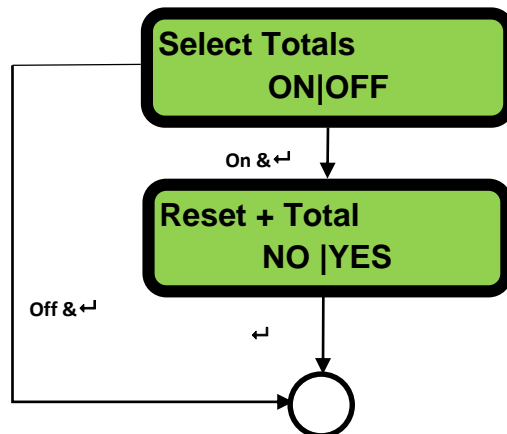
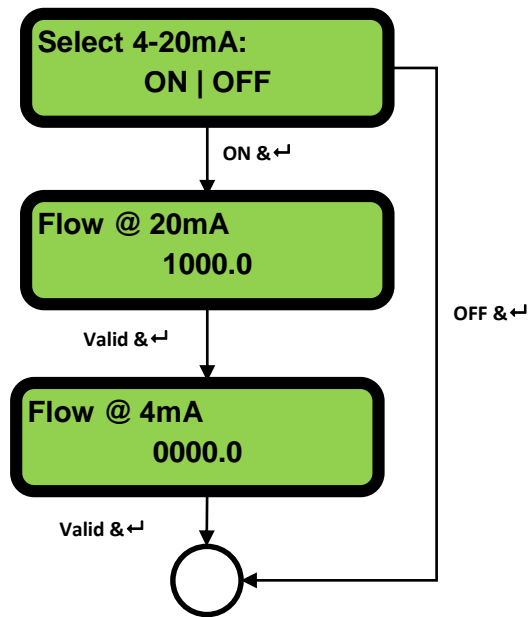

Figure 15 Pulse Output & Totaliser Menus

CURRENT OUTPUT MENU



CALIBRATION MENU

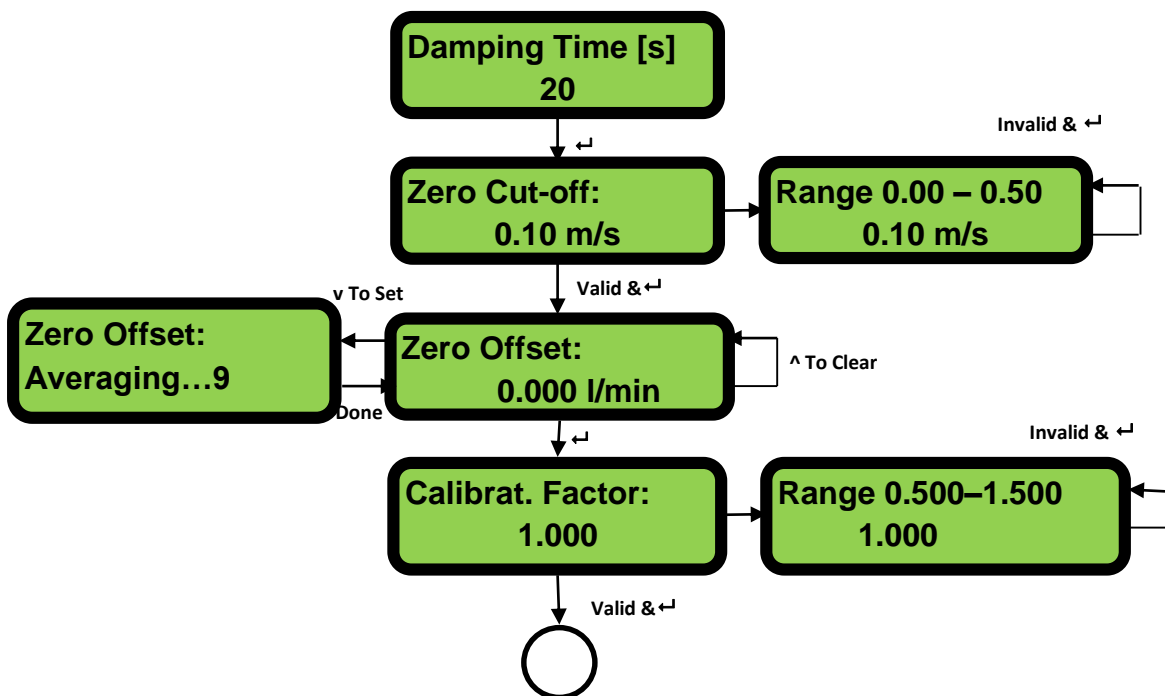



Figure 16 Current Output & Calibration Menus

9 Diagnostics Menu

The diagnostics menu provides some additional information about the flowmeter and its setup. The menu can be accessed by pressing the  key from the main flow-reading screen. The menu shown below describes the various diagnostics items.

DIAGNOSTICS MENU

Pre  To exit the Diagnostics menu

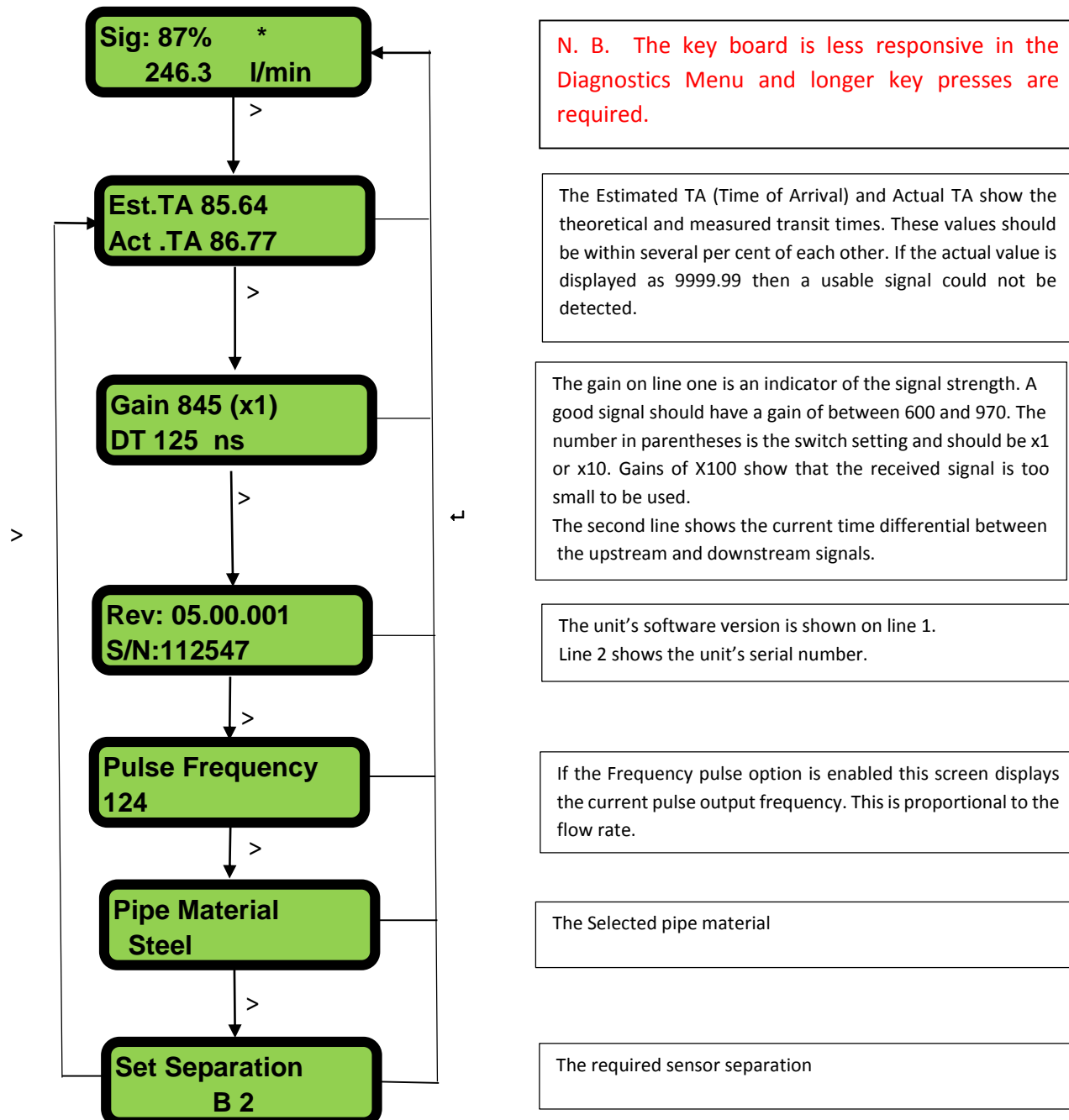
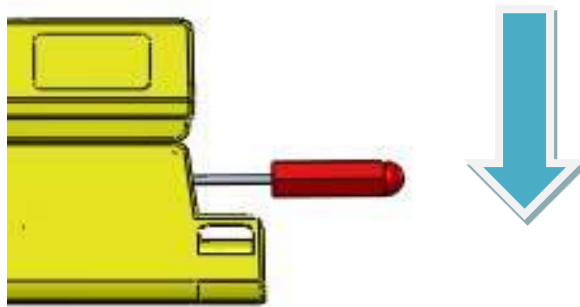

Figure 17 Diagnostics Menu

10 Relocation of guide rail

If it is necessary to relocate the guide rail and sensor assembly use the following procedure

1. Remove complete assembly from the pipe
2. Insert a small screwdriver in the hole at the end of the guide rail moulding and lever up the clip holding the electronics assembly by pressing down on the screwdriver as shown below.
3. Repeat 2 on the other end and then pull off the electronics unit.
4. Disconnect the sensors



5. Remove the original grease from the sensors
6. Push the sensor blocks into the guide rail so that the washers and locking screws can be refitted.
7. Place a bead of grease down the centre of the sensor block using the syringe provided. See illustration on fitting the guide rail to the pipe for recommended bead size.
8. Follow the original procedure for installing the guide rail on the pipe.

11 Appendix I – U1000-U Specification

Table 1 lists the U1000-U Product Specification.

General	
Measuring Technique	Transit time
Measurement channels	1
Timing Resolution	±50ps
Turn down ratio	200:1
Flow velocity range	0.1 to 10m/s
Applicable Fluid types	Clean water with < 3% by volume of particulate content.
Accuracy	±3% of flow reading for flow rate >0.3m/s
Repeatability	±0.5% of measured value
Selectable units	Velocity: m/s, ft/s Flow Rate:l/s, l/min, gal/s, gal/min, USgal/s, USgal/min, m ³ /min, m ³ /hr Volume: litres, m3, gals, USgals
Totaliser	8 digits with roll over to zero
Languages supported	English only
Power input	12 – 24V ac or dc
Power consumption	7VA maximum
Cable	5m screened 6 core
Pulse Output	
Output	Opto-isolated MOSFET volt free normally open contact.
Isolation	2500V
Pulse width	Default value 25ms; programmable range 3 – 99ms
Pulse repetition rate	Up to 166 pulses/sec (depending on pulse width)
Frequency mode	200 Hz maximum
Maximum load voltage/current	48V AC / 500mA
Current Output (If fitted)	
Output	4 – 20mA
Resolution	0.1% of full scale
Maximum load	620Ω
Isolation	1500V opto-isolated
Alarm current	3.5mA
Enclosure	
Material	Plastic Polycarbonate
Fixing	Pipe mountable
Degree of Protection	IP54
Flammability Rating	UL94 V-0
Dimensions	250mm x 48mm x 90mm (electronics + guide rail)
Weight	0.5kg
Environmental	
Pipe temperature	0°C to 85°C
Operating temperature (Electronics)	0°C to 50°C
Storage temperature	-10°C to 60°C
Humidity	90% RH at 50°C Max

Display	
LCD	2 line x 16 characters
Viewing angle	Min 30°, Max 40°
Active area	83mm (W) x 18.6mm(H)
Keypad	
Format	4 key tactile feedback membrane keypad

12 Appendix II – Default values

The settings will be configured at the factory for either metric or imperial units. Table 2 lists the metric default values.

Table 2 System Default Values

Parameter	Default Value
Dimensions	mm
Flow Rate	l/min
Pipe size	50 (mm)
4-20mA	On, 4-20mA selected
Flow at Max Current	Equivalent to 2m/s
Flow at Min Current	0
Pulse Output	On
Volume per Pulse	10 litres
Pulse Width	25ms
Damping	20 seconds
Calibration Factor	1.000
Zero Cut-off	0.10m/s
Zero Offset	0.000l/min

Table 3 lists the default values when Imperial dimensions are selected.

Table 3 System Default Values

Parameter	Default Value
Dimensions	inches
Flow Rate	USgal/min
Pipe size	2 (inches)
4-20mA	On, 4-20mA selected
Flow at Max Current	Equivalent to 2m/s
Flow at Min Current	0
Pulse Output	On
Volume per Pulse	10 US gallons
Pulse Width	25ms
Damping	20 seconds
Calibration Factor	1.000
Zero Cut-off	0.10m/s
Zero Offset	0.000gal/min

13 Appendix III – Error and Warning Messages

System errors

There are three possible 'System Error' messages that can be displayed. These are:

1. **Poor Signal.** The unit is unable to detect a signal from one or both transducers. If this message persists the sensors will need to be relocated.
2. **Pulse Overflow.** The value for the 'Vol per pulse' is set too low. Increase the Vol per Pulse setting in the password-controlled menu.
3. **No BBME:** This indicates a unit failure. Reset the unit by turning the power on and off. Contact your supplier if the problem persists.

Flow warnings

A signal strength of less than 40% indicates poor set up of the instrument, and the installation should be checked or possibly moved to a different site. A negative flow is indicated by an "!" being displayed on the top line instead of a "*".

Warnings

These generally advise the user that the data entered is out of the specified range.

1. When an invalid Pipe ID is entered, the warning message shown below is displayed, prompting the user to enter a value between 20 and 110mm.



Range 20 – 110mm
0.000 mm

2. When the 4-20mA current output is turned ON, the Flow at Maximum and Minimum current can be changed under password control. The valid range is 0 – 99999.0 If an invalid value is entered the following warning message is displayed:

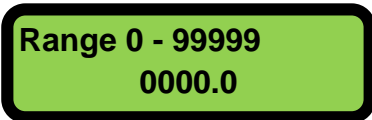

Range 0 - 99999
0000.0

3. When programming a Frequency Pulse output the frequency is limited to the range 1 to 200 Hz. If an invalid value is entered then the following warning message is displayed.



Range 1 - 200
200

4. When programming a Volume Pulse output the pulse width is limited to the range 3 to 99ms. If an invalid value is entered then the following warning message is displayed.

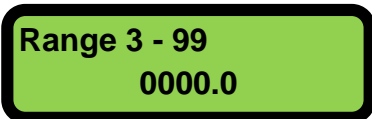

Range 3 - 99
0000.0

5. When programming the Zero Cut-off this is limited to the range 0.000 to 0.500. If an invalid value is entered then the following warning message is displayed.

Range 0.00 – 0.500
0000.0

6. When programming the Calibration Factor this is limited to the range 0.5 to 1.5. If an invalid value is entered then the following warning message is displayed.

Range 0.500 – 1.500
0000.0



micronics

CE Declaration of Conformity

Micronics Ltd

Knaves Beech Business Centre
Davies Way, Loudwater,
High Wycombe, Bucks.
HP10 9QR

The Products Covered by this Declaration Ultrasonic flow meter U1000

This product is manufactured in accordance with the following Directives and Standards.

Directive 2004/108/EC of the European Parliament and of the Council of 15 December 2004 on the approximation of the laws of the Member States relating to electromagnetic compatibility

Directive 2006/95/EC of the European Parliament and of the Council of 12 December 2006 on the harmonisation of the laws of Member States relating to electrical equipment designed for use within certain voltage limits

The Basis on which Conformity is being Declared

The manufacturer hereby declares under his sole responsibility that the products identified above comply with the protection requirements of the EMC directive and with the principal elements of the safety objectives of the Low Voltage Equipment directive, and that the following standards have been applied:

BS EN 61010-1:2001 Safety requirement for electrical equipment for measurement control and laboratory use. Part 1 General requirements

BS EN61326-1:2006 Electrical equipment for measurement control and laboratory use EMC requirements. Part 1: General requirements

BS EN61326-2-3:2006 Electrical equipment for measurement control and laboratory use EMC requirements. Part 2-3: Particular requirements – Test configuration and performance criteria for transducers with integrated or remote signal conditioning.

The technical documentation required to demonstrate that the products meet the requirements of the Low Voltage Equipment directive has been compiled and is available for inspection by the relevant enforcement authorities. The CE mark was first applied in: 2012

Signature:

Printed Name:

Michael Farnon

Title:

Managing Director

Date:

2nd August 2012

Attention!

The attention of the specifier, purchaser, installer, or user is drawn to special measures and limitations to use which must be observed when these products are taken into service to maintain compliance with the above directives.

Details of these special measures and limitations to use are available on request, and are also contained in the product manuals.

Registered Office: Micronics Limited, Knaves Beech Business Centre, Davies Way, Loudwater, Buckinghamshire, HP10 9QR

Web site www.micronicsflowmeters.com Tel: +44 (1628) 810456 Fax: +44 (1628) 531540

Directors E.J. Farnon, M.A. Farnon

Registration No. 1289680 V.A.T Registration No. 303 6190 91