

R Series

ROTARY POSITIVE DISPLACEMENT PUMPS



SPX R Series Rotary Pumps are known all over the world for their rugged, long lasting design and efficient performance. Backed by a worldwide sales, engineering and service organization, R Series Rotary Pumps are designed and built in a modern manufacturing facility using the latest programmable automated machine tools. Each component must meet rigid quality control standards. SPX offers an exceptional range of capacities, rotor types, mounting configurations and options. The exclusive resilient rotors form a continuous flexible seal between suction and discharge. Product flow is positive, continuous, non-agitating and completely controlled at all times.

R Series Positive Displacement Rotary Pumps

PRODUCT FEATURES AND BENEFITS

- Simple design – few parts
 - Ideal for manually cleaned applications – Clean out of Place
 - Can be disassembled in few minutes
 - Strong structure
 - Floating rotors – no shimming required
1. Front cover is constructed of precision ground stainless steel for tight sealing with the pump body.
 2. Gasket is made up of a specially formulated paper assuring dimensional accuracy.
 3. Precision molded rubber rotors available with either plastic or stainless steel hubs.
 4. Shaft lip seals are molded in a variety of compounds for both pressure and vacuum applications.
 5. One piece stainless steel pump body is machined and polished for easy cleanup.
 6. Seal bearing slips over o-ring and rotor shaft to provide easily replaceable seal surface.
 7. Stainless steel studs, assures quick and proper assembly.
 8. Heavy duty cast iron gear case housing provides oil reservoir for timing gears and shaft bearings; exterior is finished with a high quality heat and chemical resistant epoxy paint.
 9. Rear cover contains oil seals and shaft bearing adjustment nuts.
 10. The drive shaft is provided with a standard key way and can be supplied in either top or bottom location. (Either left or right location for top feed configurations.)
 11. Heavy duty tapered roller type shaft bearings are standard.
 12. Precision machined spur timing gears are hardened for long, quiet operation and are welded to the rotor shaft to assure accurate timing.
 13. Locating plugs are pressed into the gear case providing accurate positioning of the pump body.
 14. A leak detection atmosphere is present between the pump body and gear case ensuring high protection of product zone.
 15. A special locating corner found on the stainless steel shaft ensures proper rotor installation.

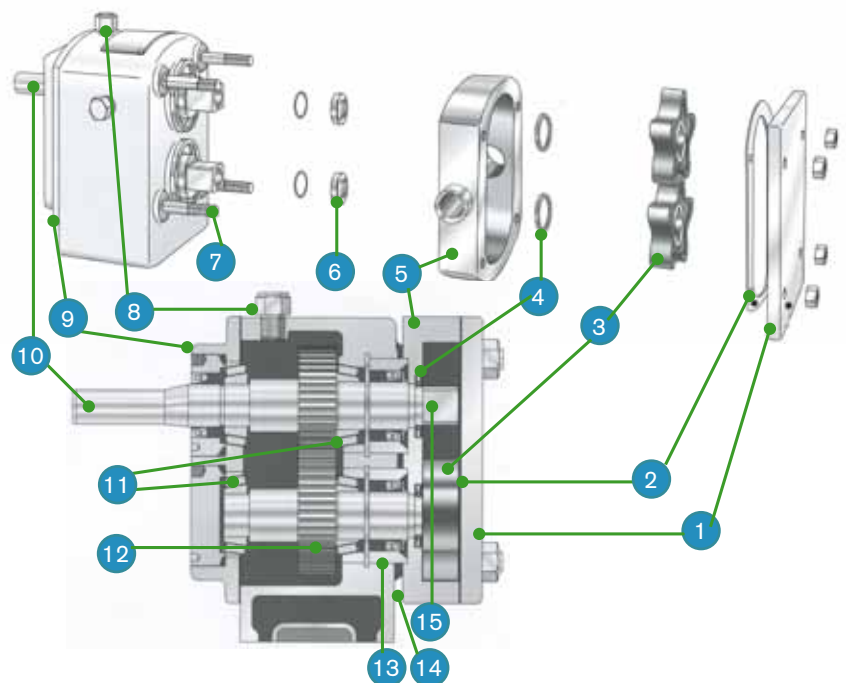

Typical product applications

THEORY OF OPERATION:

R Series Rotary Pumps incorporate a long life, sanitary, stainless steel body with versatile, resilient, molded rotors and a heavy duty cast iron gear case – all of which are designed to give dependable, economical service over a wide range of products and applications. All product contact parts are 316 stainless steel with food grade seal and rotor materials which will not impart odors or affect flavors. All parts are interchangeable and replaceable in the field.

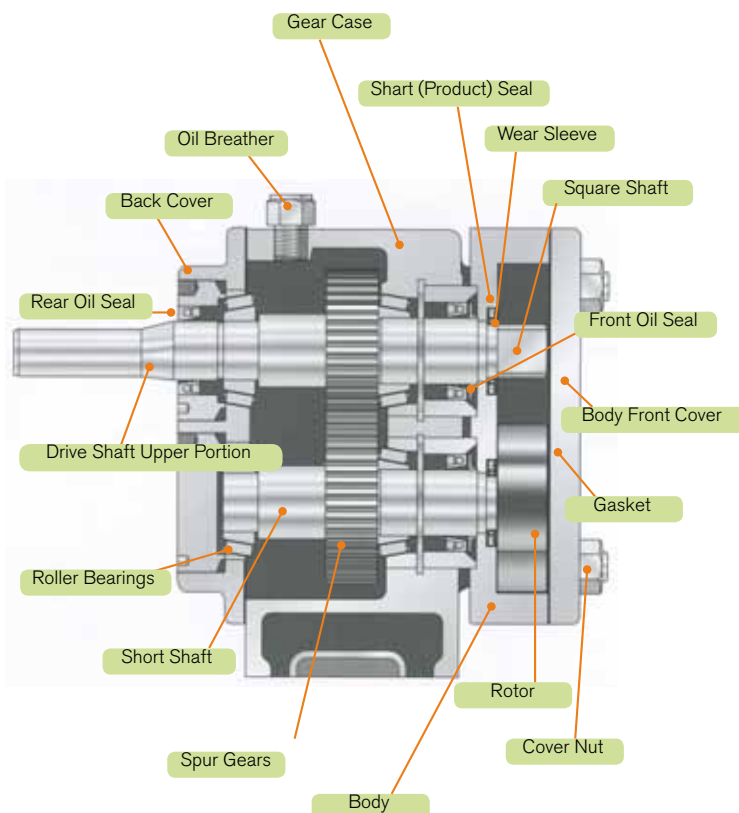

Beverage

- Fruit Juice
- Cider and Wine
- Yeast
- Liquid Sugar and Glucose



Food

- Fruit Preserves
- Soups and Sauces
- Baby Food
- Chocolate



Pharmaceutical and Toiletries

- Antibiotics
- Toothpaste
- Cough Medicine
- Shampoo



Dairy

- Cream
- Butter
- Cheese Curd & Whey
- Yogurt
- Ice cream



Chemical

- Paint
- Oil Additives
- Resins
- Photographic Film Coatings



PRODUCT SPECIFICATIONS

MODEL SIZES								
		0	1	2	3 AND 3 HD	4 AND 4 HD	6 AND 6 HD	700 HD
Maximum Capacity*	gpm	2.5	6	9	55	145	240	200
	m ³ /hr.	0.57	1.36	2.0	8.2	20.4	34.1	45.4
Displacement per 100 revolutions	Gal/100 rev.	0.46	1.0	1.5	6.4	17.5	29.0	58.0
	liter/100 rev.	1.75	3.88	5.8	24.3	66.2	111	220
Maximum RPM		600	600	600	900	900	900	400
Connection Sizes (Standard)	in	1.5	1.5	1.5	2	2 or 3	3	4
	mm	38	38	38	51	51 or 76	76	102
Rectangular Inlet (Optional)	in	N/A	N/A	.875 x 2.5	1.5 x 4.5	1.75 x 9.25	3 x 9.25	6.625 x 9.25
	mm	N/A	N/A	22 x 63	38 x 114	44 x 235	76 x 235	168 x 235
Maximum Power Requirement**	BHP	0.5	0.9	1.5	7.5	20	30	20
	Kw	0.37	0.67	1.12	5.6	14.9	22.4	15
Rotors	Number of Lobes	2	5	5	5	5	5 and SGL	5 and SGL
	Material	R	R	R	R, SE, and M	R, SE, and M	R, SE, and M	R, SE, and M

* Based on 70°F (21°C) water at 0 psi.

**Maximum power requirement increases with product viscosity.

R = Rubber SE = Sealed Epoxy M = Metal SGL = Single

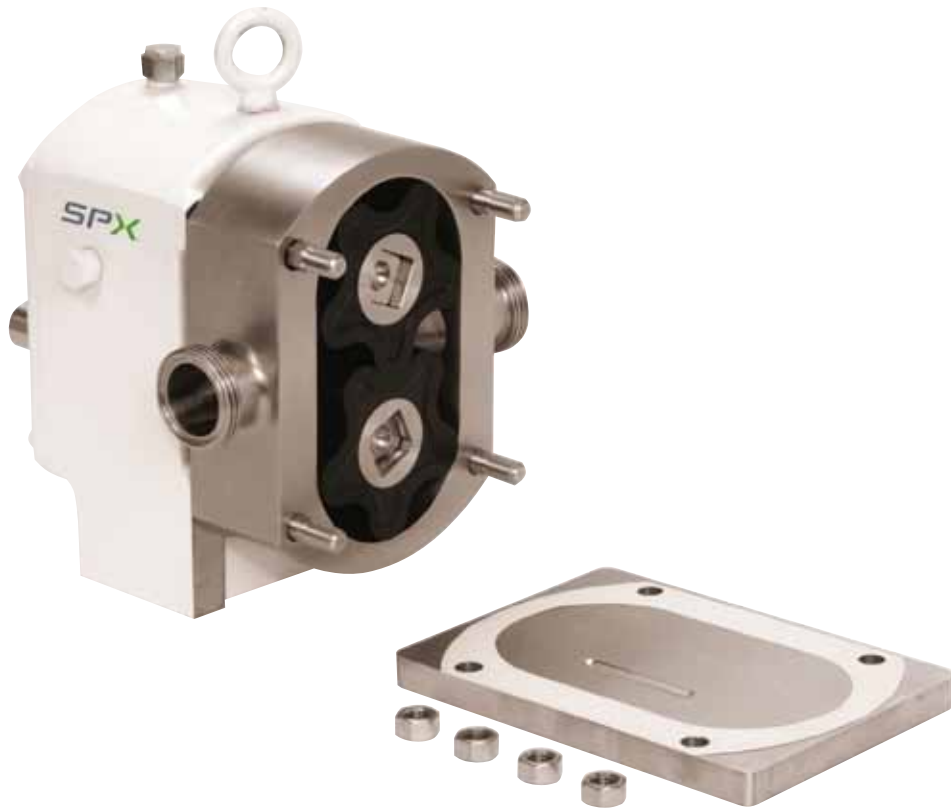

ADDITIONAL TECHNICAL DATA

Performance curves are available for all R Series Pumps. The following is an example of an R Series Curve.

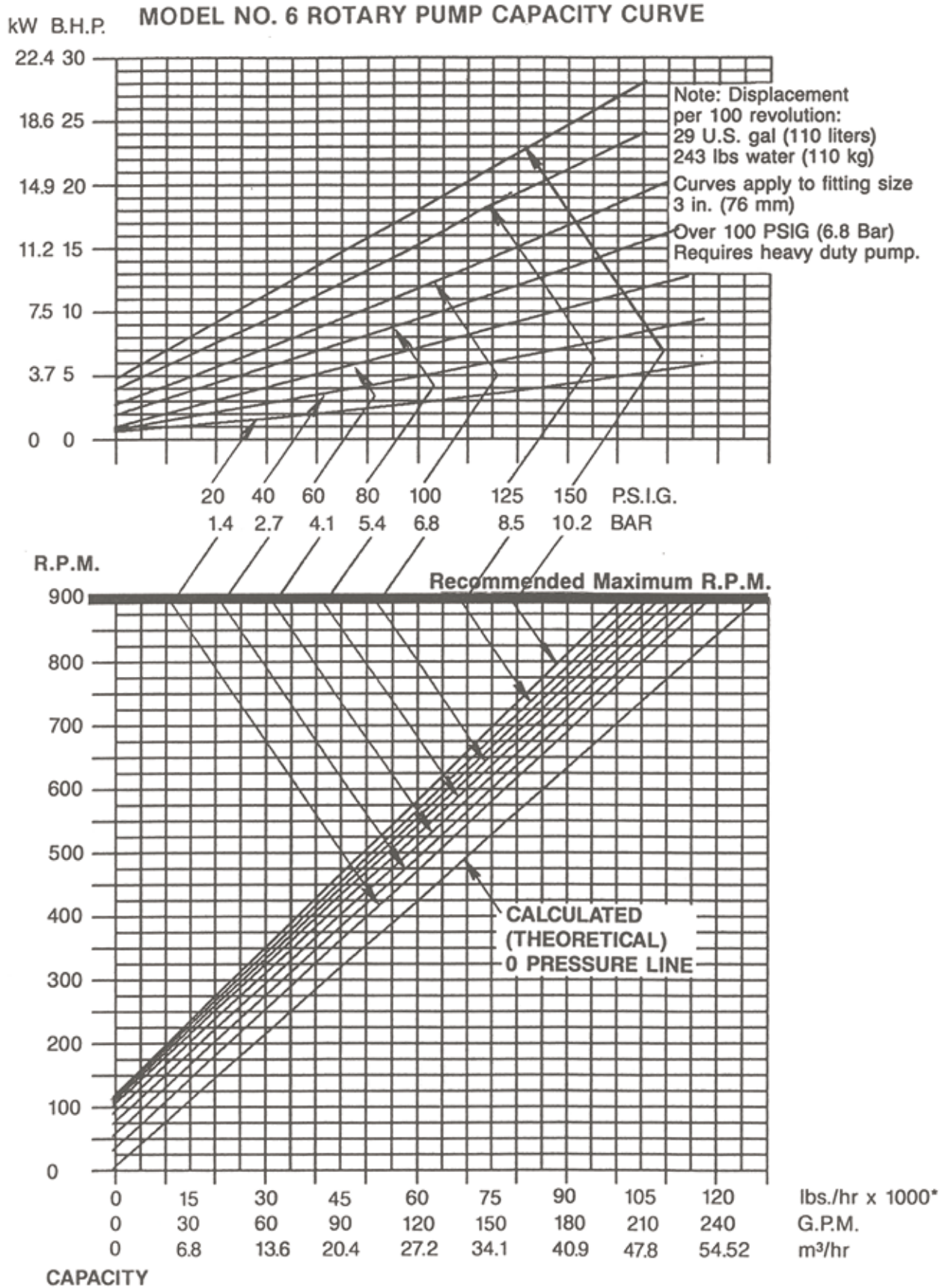

OPTIONS AND ACCESSORIES

Body and Mounting Configurations

Side Inlet/Outlet is the basic standard design for all size SPX Rotary Pumps used for pumping light to medium viscosity products.



Feed Inlets:

The top feed and top feed-rectangular inlets are used when product is flowing down through outlet tanks or hoppers. The top feed-rectangular configuration is similar to the top feed design but with a large rectangular inlet replacing the standard round connection. The larger inlet accommodates heavy viscous products, or products with large particulates or chunks. Both include a removable pedestal support. The top feed inlet is available in all sizes while the top feed-rectangular inlet is available in pump sizes 2 RI through 700 RI.



The side feed-rectangular inlet is designed to adopt to the discharge of an auger feed hopper, grinder, blender or specialty hopper and is available in pump sizes 4 RI through 700 RI.

Front Covers

Standard flat cover for applications up to 100 psi (6.8 bar) discharge pressure.



Heavy Duty cover contains outboard bearing support to accommodate extended pump shafts for applications with discharge pressures higher than 100 psi (6.8 bar).



Vented cover is available with manual or pneumatic control and is used to limit maximum discharge pressure at a predetermined setting. Not available on size 0 or heavy duty pumps.



Degassing/Deaerating cover incorporates relief grooves and manifold to relieve trapped gas/air in viscous products.



Front Outlet cover replaces bottom outlet normally provided on RI pumps. Allows pump to be used under low height hopper and reduces discharge piping components.

Rotor Exchange Program:

SPX offers a generous exchange program for all SPX style stainless steel hub rotors, regardless of original manufacturer!. In the exchange program, new rubber is molded around a used hub, offering users of SPX R Series pumps a fast, reliable, cost-effective method of replacing stainless steel hub rotors. By reusing otherwise discarded materials, users also help the environment.

Exchange Program Benefits Include:

- Genuine replacement rotors protect your pump warranty
- Fast turnaround direct from stock inventory
- Savings up to 30% on each reusable rotor
- Savings of 10% on a new rotor if the returned rotor is unusable
- 100% factory inspection of all returned rotors

Configurations

Precision molded and machined rotors have been the heart of the SPX R Series Rotary Pump for more than 50 years. They are performance proven and are available in a variety of designs to meet specific application requirements. All SPX rotors meet all FDA requirements.

Standard 5-Lobe with recessed faces is provided on all pump sizes 1, 2, 3, 4, 6 and 700. These exclusive SPX formulated resilient covered rotors are recommended for most applications. Normal size up to 150°F (65°C), under size up to 300°F (149°C).



Flush Face is the same specification as standard 5-lobe except the faces are smooth (flush), not recessed. Available for pump sizes 2, 3, 4, 6 and 700. Used with abrasive or clinging products that might clog recessed face. Also used in degassing/deaerating pumps with front outlet covers. Normal size up to 150°F (65°C), under size up to 300°F (149°C).



Single Lobe with recessed faces are available for pump sizes 6 and 700, same displacement as 5-lobe. Used with delicate or fragile products and large particulates or chunks. Normal size up to 150°F (65°C), under size up to 300°F (149°C). Recommended operating limitations; 200 rpm maximum, 100 psi (6.8 bar) maximum.



Seal-Materials

SPX offers four different seal options for the R Series pump. All seals have color coded dots for easy recognition:

- Nitrile (Red)
- EPDM (Orange)
- FKM (Blue)
- Neoprene (Green)
- All Seals are lip style seals



R Series

ROTARY POSITIVE
DISPLACEMENT PUMPS



Global locations

USA

SPX FLOW TECHNOLOGY

611 Sugar Creek Road
Delavan, WI 53115
+1 262 728 1900

APAC

SPX FLOW TECHNOLOGY

SINGAPORE
25 International Business Park
#03-03/12, German Centre
Singapore 609916
+65 6264 4366

EMEA

SPX FLOW TECHNOLOGY

POLAND Sp z o.o.
ul. Grunwaldzka 229
85-451 Bydgoszcz
Poland
+48 52 525 99 00

Based in Charlotte, North Carolina, SPX Corporation (NYSE: SPW) is a global Fortune 500 multi-industry manufacturing leader. For more information, please visit www.spx.com

SPX FLOW TECHNOLOGY

611 Sugar Creek Road
Delavan, WI 53115
P: (262) 728-1900 or (800) 252-5200
F: (262) 728-4904 or (800) 252-5012
E: answers.us@apv.com

SPX reserves the right to incorporate our latest design and material changes without notice or obligation.

Design features, materials of construction and dimensional data, as described in this bulletin, are provided for your information only and should not be relied upon unless confirmed in writing. Please contact your local sales representative for product availability in your region. For more information visit www.spx.com.

The green ">" is a trademark of SPX Corporation, Inc.

ISSUED 04/2014 7003-01-08-2008-US

COPYRIGHT © 2014 SPX Corporation