



APV V² Centrifugal Pumps

Maintenance-Friendly And Efficient



Moderate Head Pumping Applications

APV Fluid Handling offers an economical solution to an increasing range of pumping applications: the V² Series — a simplified, maintenance-friendly and efficient centrifugal pump featuring a four-blade, fully open, non-clog impeller that is the optimum design for sanitary service.

Features and Benefits

- Meets all standards: Sanitary models are manufactured from FDA approved materials, meet the requirements of the 3-A Sanitary Standards, carry the BISSC seal of approval and are approved by the USDA Meat and Poultry Division.
- Choice of seal types: the V² pumps are available with three different seal types to accommodate various applications and ensure optimum seal performance for the product being pumped. The standard product seal for all models is Type 1, a positive drive, single mechanical design,
- Hydraulically balanced and externally mounted. It suits general purpose applications such as milk products, beverages, fruit juices, organic acids, alcohols, process water and vegetable oils.
- Engineered for in-place cleaning: All V² Series Centrifugal Pumps are engineered for modern cleaning and sanitizing techniques. The square impeller drive has grooves that allow circulation of cleaning and sanitizing solutions along the shaft and behind the impeller. The separate impeller and shaft design enhances cleaning and inspection. Pump disassembly is quick and easy for complete manual cleaning and inspection. Parts and assemblies are not difficult to align. No special tools are required.

Typical Applications

- Milk, cream, ice cream mix
- Fruit juices, beverage syrup
- Water, beer
- Sauces, catsup, vinegar
- Yeast slurry, starch, tallow
- CIP solutions, brine, edible oils
- Pharmaceuticals
- Organic acids, alcohols

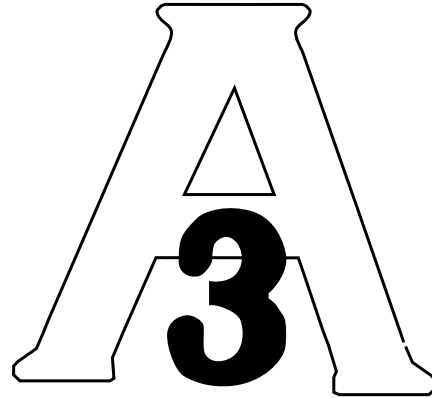

Durable Construction

The casing has controlled wall thickness and dimensional accuracy throughout. The back plate is machined from stainless steel plate. A unique clamping assembly uses clamp rings with a self-locking internal angle that resists distortion and provides optimum sealing between the casing and back plate. The clamp rings are investment cast for greater strength than stamped clamp rings common to many sanitary pumps. A replaceable seat is provided in the back plate with optional seal types #2 and #5. This is reversible, providing a new wear surface without part replacement.

Other Pump Options

- Special stainless steel polishing including electro-polish
- Non-polished stainless steel surface (industrial applications)
- Case drain connections
- Stainless steel tubular base assemblies



Construction and Design Features

1. Casing

- Heavy, single piece investment casting with uniform wall thickness
- Volute design provides good efficiency over a wide range of operating conditions
- Discharge can be rotated through 360°
- Interior of casing is free of sharp corners for easy, complete cleaning

2-3. Impeller Pin and O-Ring

- Stainless steel, attaches directly to the end of the shaft

4. Impeller

- One piece design with 4-blade, reverse curve configuration
- Open impeller eye area improves pumping efficiency and lowers NPSHR
- Square shaft and hub design promotes easy assembly/disassembly and provides maximum driving contact surface

5. Casing Gasket

- Fully retained with roll bead on the gasket back which seals in the back plate groove for trouble-free positioning and sealing

6. Back Plate

- 316 stainless steel plate
- Heavy duty to resist water hammer and effect of cavitation

7. Shaft Seal

- Standard Type 1 seal is a single mechanical, externally mounted APV design with rotating carbon seat and stationary 316 stainless steel back plate. All seals are hydraulically balanced and positive driven

8. Drive Ring

9. Seal O-Ring

10. Spring

11. Impeller Shaft

- Precision machined to ensure concentricity and balance
- Locking collar design to assure strong, positive attachment

12. Safety Guard

- Perforated stainless steel meets OSHA requirements
- Protects the shaft/seal area

13. Adapter

- Stainless steel construction for strength and rigidity
- Large access for shaft positioning

14. Screw for Adapter

15. Shaft Collar

16. Clamp Ring

- Investment cast for strength with proprietary tapered clamp design to improve sealing and hold casing and back plate tight against adapter
- Fast disassembly without special tools

17. Adapter Plate — Only on larger motor frames

18. Screw for Motor

Legs

- Black feet as standard
- Stainless steel (4) on sanitary models — as option only

Connections

- Butt weld, plus five sanitary ferrule options
- 150 lb ANSI flange and male pipe thread for non-sanitary applications

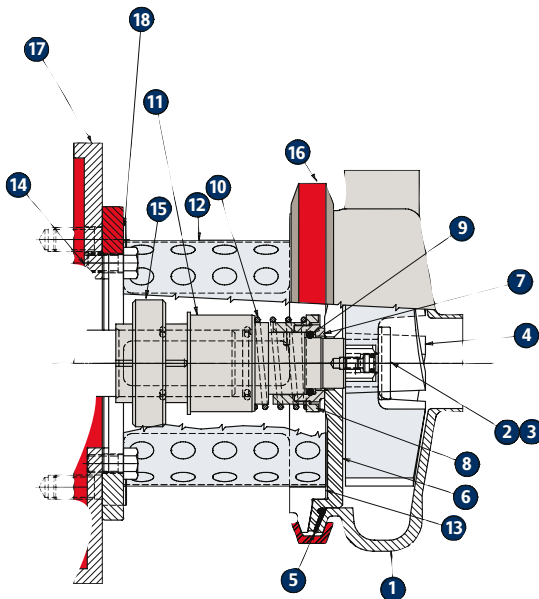
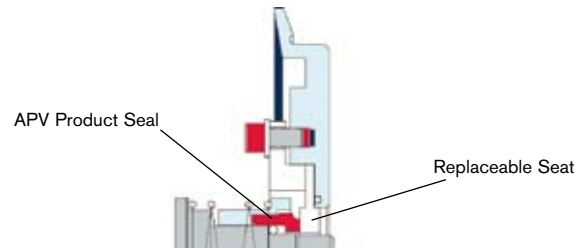

Seal Options

- Type 2 APV product seal/ replaceable seat
 - Replaceable seat provides a harder, wear-resistant stationary seat for extended life
- Cascade Water Flush
 - For Type 1 and Type 2
 - Recommended for products containing fines or particulates: brines; low vacuums; where caramelization may occur (liquid sugars, HFCS, honey, syrups, molasses); and where flush water can discharge onto floor
- Type 5 contained water flush double seals (APV & John Crane)/replaceable seat
 - Double inside/outside APV hydraulically balanced inside; John Crane 8B2 hydraulically balanced outside

Prepared for the Future

PUMP MODEL	UNIT	PUMP CASING INLET x OUTLET	MAXIMUM IMPELLER SIZE	PERFORMANCE AT B.E.P.				Data summary listed are inlet, outlet and impeller sizes, along with the Best Efficiency Point and shut-off head for each model. Capacity (Q) shown in U.S. GPM. Impeller diameter shown is maximum. Certified dimensional drawings are available on request.
				1,750 RPM		3,500 RPM		
				Q GPM (m/hr)	HEAD FT (m)	Q GPM (m/hr)	HEAD FT (m)	
4V ² - 14V ²	in	1.5 x 1.5	3.8	37	13	74	45	
	mm	38 x 38	97	8.4	4	16.8	13.7	
4V ² - 14V ²	in	2 x 1.5	3.8	42	13	84	52	
	mm	51 x 38	97	9.5	4	19.1	15.8	
6V ² - 16V ²	in	2 x 1.5	5.8	85	33	158	143	
	mm	51 x 38	148	19.3	10	35.9	43.6	
6V ² - 16V ²	in	2.5 x 1.5	5.8	80	36	160	144	
	mm	63 x 38	148	18.2	11	36.3	43.9	
8V ² - 18V ²	in	2 x 1.5	7.8	117	37	234	266	
	mm	51 x 38	200	26.6	20.4	53.2	81.7	
8V ² - 18V ²	in	3 x 2	7.8	137	63	274	252	
	mm	76 x 51	200	31.1	19.2	62.2	76.8	
8VS ² - 18VS ²	in	3 x 2	7.8	231	63	462	252	
	mm	76 x 51	200	52.5	19.2	104.9	76.8	

FLOW, HEAD (BEST EFFICIENCY POINT) @ RPM

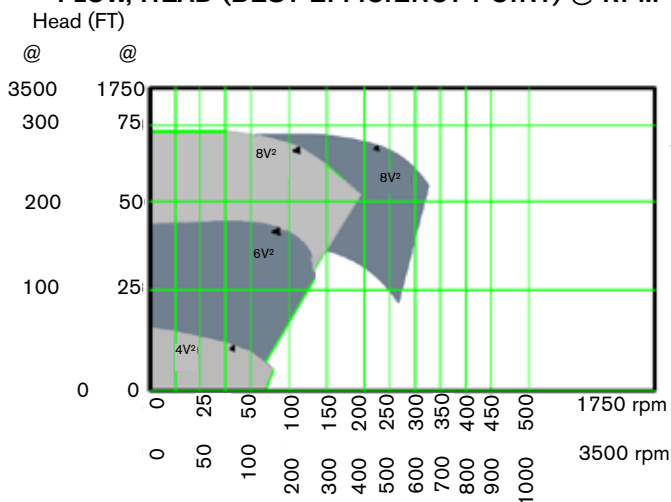

Composite Performance Curves for the V² Series

The arrows indicate the Best Efficiency Point (B.E.P.) for various pump models. Individual performance curves are available upon request.



Your local contact:



APV, An SPX Brand
 Phone: (888) 278-4321
 Email: answers.us@apv.com

For more information about our worldwide locations, approvals, certifications, and local representatives, please visit www.apv.com.

SPX Corporation reserves the right to incorporate our latest design and material changes without notice or obligation.

Design features, materials of construction and dimensional data, as described in this bulletin, are provided for your information only and should not be relied upon unless confirmed in writing.