

UNIVERSAL DIFFERENTIAL pH AND ORP SENSORS

For Use with Conventional pH/ORP Transmitters



RECOMMENDED APPLICATIONS:

- Wastewater Treatment
- Drinking Water Treatment
 - Odor Scrubbers
 - Food Processing
 - Metal Finishing
 - Pulp and Paper
- Chemical Processing

Employs differential measurement technique

Buffered reference cell solution resists contamination

Complete encapsulation protects internal electronics

Superior accuracy through elimination of ground loops

Chemically-resistant Ryton® PPS body

Two year limited warranty

Differential sensors have longer working lifetimes

The differential design employs two glass electrodes, which record pH or ORP measurements differentially with respect to a third metal electrode. The reference cell of a differential sensor is actually a measuring electrode in a concentrated pH 7.0 buffer solution rather than a traditional silver/silver chloride reference. This type of reference cell resists contamination by the sample, improving measurement accuracy and extending sensor lifetime.

Save time and money with quick and easy maintenance

With differential technology, you won't have to replace the entire sensor after just a few months. Simply replace the salt bridge and refill the reference solution to keep your electrode working longer.

Don't want to replace your existing transmitter or controller?

These differential sensors employ a self-powered preamplifier, providing a combination sensor output for deployment flexibility with various transmitters and controllers.

COMPATIBLE TRANSMITTERS:

- Sensorex TX10
- Sensorex TX100
- Sensorex TX2000
- And More!

DESIGNED AND ASSEMBLED IN CALIFORNIA, USA

11751 MARKON DRIVE • GARDEN GROVE, CA 92841 • 714.895.4344 • WWW.SENSOREX.COM

© Sensorex Corporation. All rights reserved. In the interest of improving and updating its equipment, Sensorex reserves the right to alter specifications to equipment at any time.

OUTLINE AND DIMENSIONS

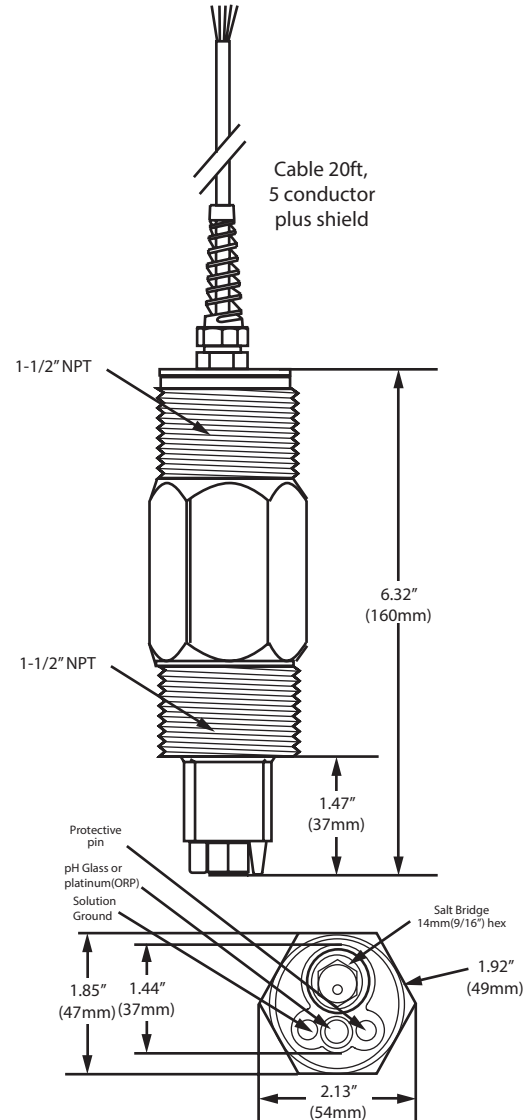

SPECIFICATIONS

pH Measurement Range:	0 to 14
ORP Measurement Range	-2000mV to 2000mV
pH Stability	0.03pH per 24 hours, non-cumulative
Wetted Materials	PPS body and salt bridge, PVDF & ceramic junction, Viton o-rings, titanium solution ground, pH glass or ORP - platinum band
Transmission Distance:	3000ft (914m)
Temperature Compensation:	PT1000 RTD
Temperature Range:	0-85°C (32-185°F)
Pressure Maximum:	100psig @ 40°C (104°F)- for PVC tee/ fitting 100psig @ 60°C (140°F)- for CPVC tee/fitting 100psig @ 85°C (185°F)- for stainless steel tee/ fitting
Flow Rate	10ft/sec maximum (3 meters/sec)
Sensor Cable	5 conductor plus shield, 22AWG, 20ft (6.1m)

ORDERING INFORMATION

Part Number	Description
SD7500CD	Self-powered differential pH sensor for use with conventional pH transmitters, 20ft cable, tinned leads, 1.5" NPT mounting
SD7500CD-ORP	Self-powered differential ORP sensor for use with conventional ORP transmitters, 20ft cable, tinned leads, 1.5" NPT mounting
SDA-7001	Salt bridge for SD7500CD & SD7500CD-ORP, 1 each
SDA-7003	Salt bridge for SD7500CD & SD7500CD-ORP, 3 each
SDA-7010	Salt bridge for SD7500CD & SD7500CD-ORP, 10 each
SDS-7015	Standard cell refill solution, 125mL